

CONSTRUCTION DRAWINGS

APRIL 7, 2023

# PETERSBURG PARKS AND RECREATION

WASTE LINE REPAIR

FOR THE

## PETERSBURG BOROUGH PARKS AND RECREATION

500 N 3RD ST.

PETERSBURG, ALASKA

RSA

Engineering, Inc.

MECHANICAL AND ELECTRICAL CONSULTING ENGINEERS  
670 West Fireweed Lane, Suite 200  
Anchorage, AK 99503  
Phone (907) 276-0521  
Corporate No.: AECC542

P | N | D ENGINEERS, INC.

9360 Glacier Highway, Ste 100 Phone: 907.586.2093  
Juneau, Alaska 99801 Fax: 907.586.2099

Hildie A. Cain, Architect  
(907)529-5167 ccsak@hotmail.com  
www.hcarchitecture-ak.com



### INDEX TO DRAWINGS:

G100	COVER SHEET
A100	FINISHES DEMOLITION
A101	PHOTOS
A200	FINISHES SCHEDULE DETAILS
A300	ARCHITECTURAL SPECIFICATIONS
A301	ARCHITECTURAL SPECIFICATIONS
S100	STRUCTURAL GENERAL NOTES, PLAN AND DETAIL
M001	LEGENDS, SCHEDULES, AND ABBREVIATIONS
M002	MECHANICAL SPECIFICATIONS
M101	UNDER SLAB PLUMBING DEMOLITION PLAN
M102	ABOVE FLOOR PLUMBING DEMOLITION PLAN
M201	UNDER SLAB PLUMBING REMODEL PLAN
M202	ABOVE FLOOR PLUMBING REMODEL PLAN

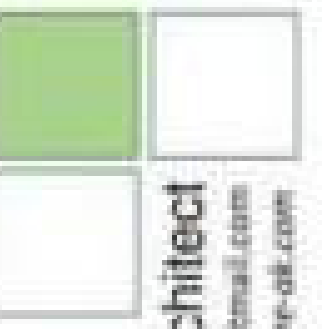
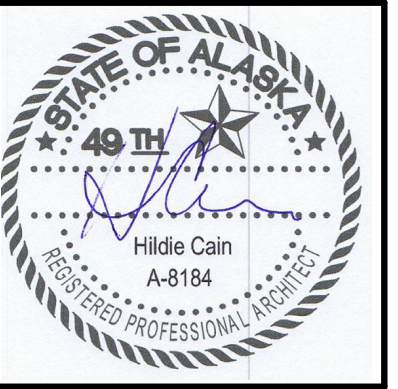

Hildie A. Cain, Architect  
1007525-5187 - ccain@hacmail.com  
www.harchitecture-ak.com

DEMOLITION NOTES

- 1 Remove existing upper and lower casework, complete.
- 2 Remove existing sink, supply and drain lines. Leave drain in place in wall to accommodate new sink. Reference new work.
- 3 Remove and salvage existing elevated floor tile as required. Retain floor tiles for reinstallation. Reference new work.
- 4 Remove existing flooring and adhesive, complete. Retain existing wood base where it occurs.
- 5 Remove existing floor tile, base and adhesive if required for underfloor work, complete room. At areas where flooring and base are removed, prepare floor for new finishes. Reference new work.
- 6 Remove and salvage existing bench. Reinstall bench and base when work is complete. Reference new work.
- 7 Demolish concrete floor as required to complete underfloor work.
- 8 Demolish existing flooring, adhesive and rubber base.
- 9 Remove and salvage existing rubber tile as required to accomplish under-floor work. Reference new work.
- 10 Remove existing door and hardware as required to accomplish under-floor work. Reinstall at completion.

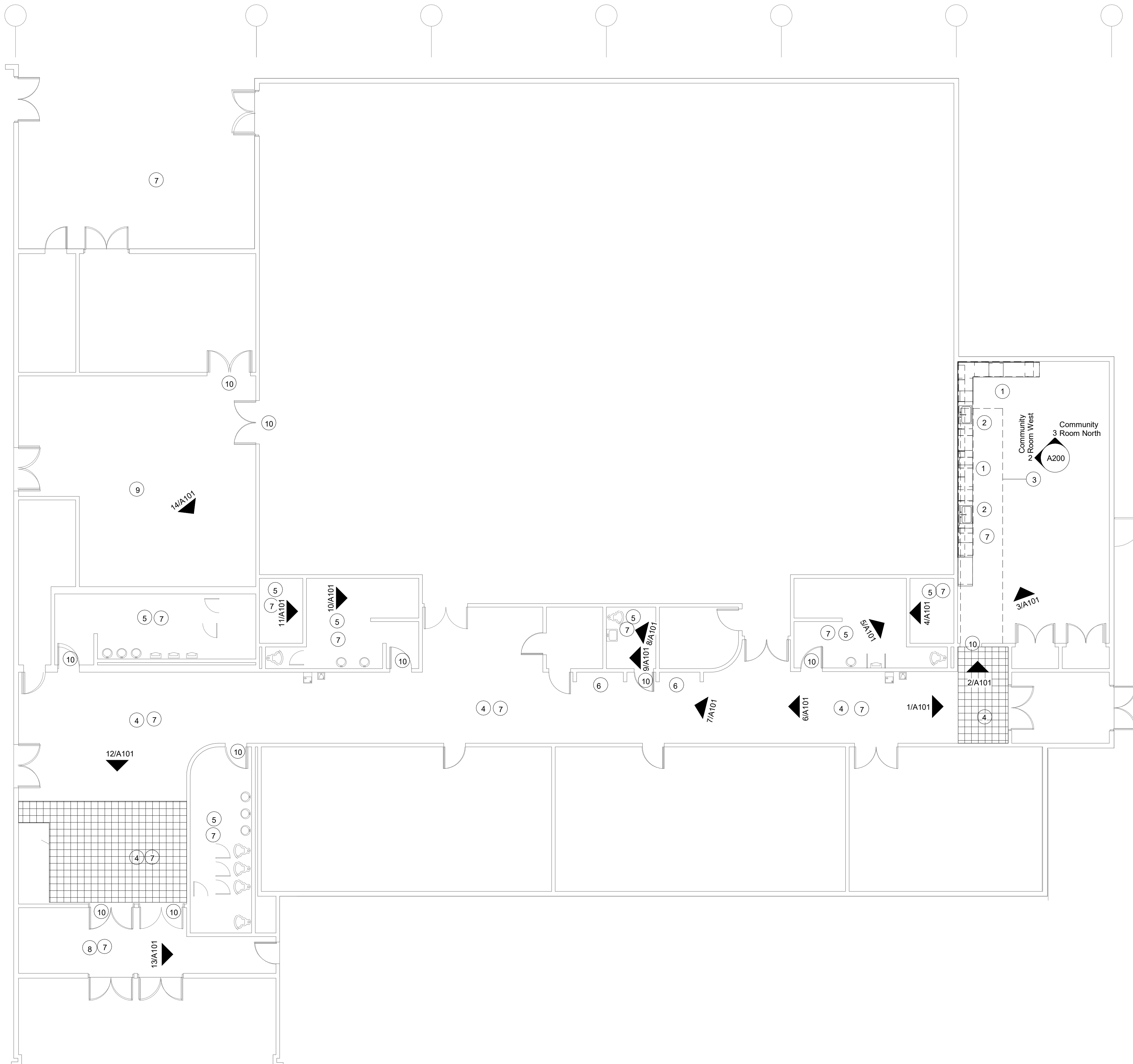

1 Demolition Plan  
1/8" = 1'-0"

PARKS & REC. WASTE PIPE REPAIR

PETERSBURG BOROUGH  
500 N. 3RD. ST.  
PETERSBURG ALASKA 99833

REVISIONS:

DRAWN BY:

CHECKED BY:

DATE: 4/7/2023

JOB NUMBER: 2311

DRAWING TITLE:

FINISHES  
DEMOLITION

SHEET:

A100



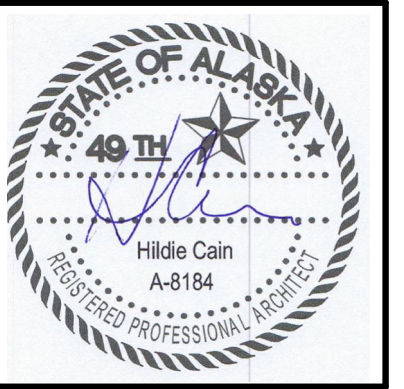

Hildie A. Cain, Architect  
REGISTERED PROFESSIONAL ARCHITECT  
NO. 0075729-5187 - ccain@hacmail.com  
www.hacarchitecture-ak.com

**PARKS & REC. WASTE PIPE REPAIR**  
PETERSBURG BOROUGH  
500 N. 3RD. ST.  
PETERSBURG ALASKA 99833

REVISIONS:

DRAWN BY:  
CHECKED BY:  
DATE: 4/7/2023  
JOB NUMBER: 2311

DRAWING TITLE:  
PHOTOS

SHEET:  
A101

1"  
2"  
3"

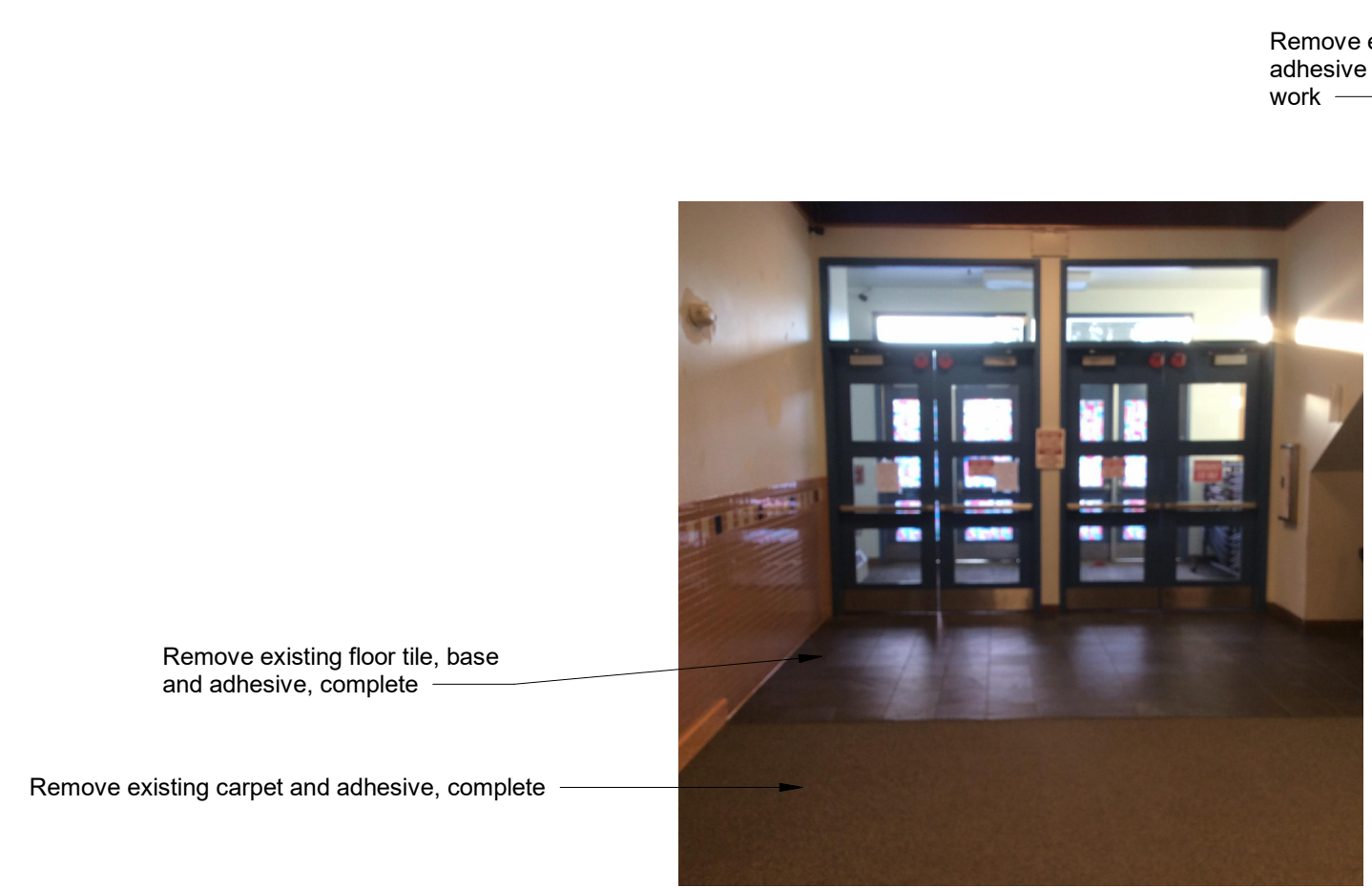

Remove existing floor tile, base and adhesive, complete  
Remove existing carpet and adhesive, complete

PH 12 - West Entry



Remove existing floor tile, base tile and adhesive as required to accomplish under-floor work

PH 8 - Accessible Restroom

Remove floor mounted equipment, reinstall at completion



Remove existing floor tiles, base tiles and adhesive as required to accomplish under-floor work

PH 4 - Boys Locker Room

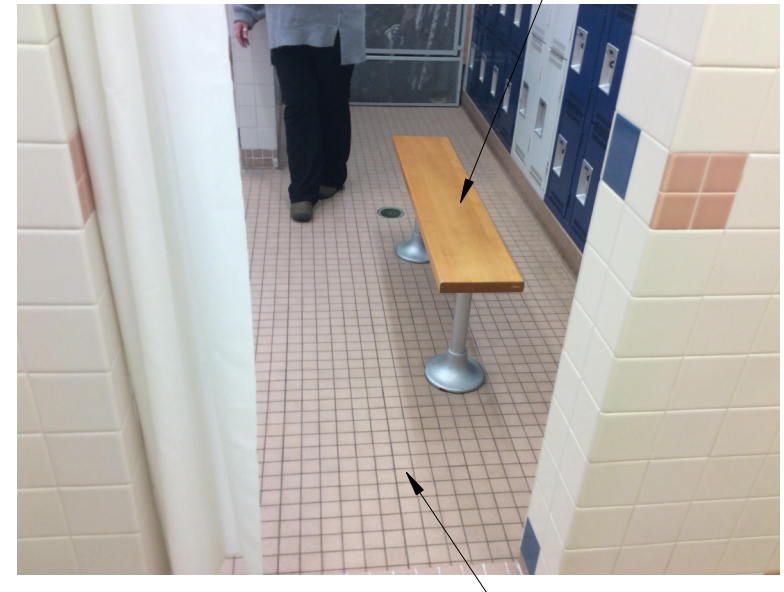

Remove all floor mounted equipment. Reinstall at completion.

Existing bench to remain. Remove wood surface and store for reinstallation.

Remove existing wood base, complete

PH 11 - Girls Locker Room

Demolish existing floor tiles, base tiles, and adhesive as required to accomplish under floor work.

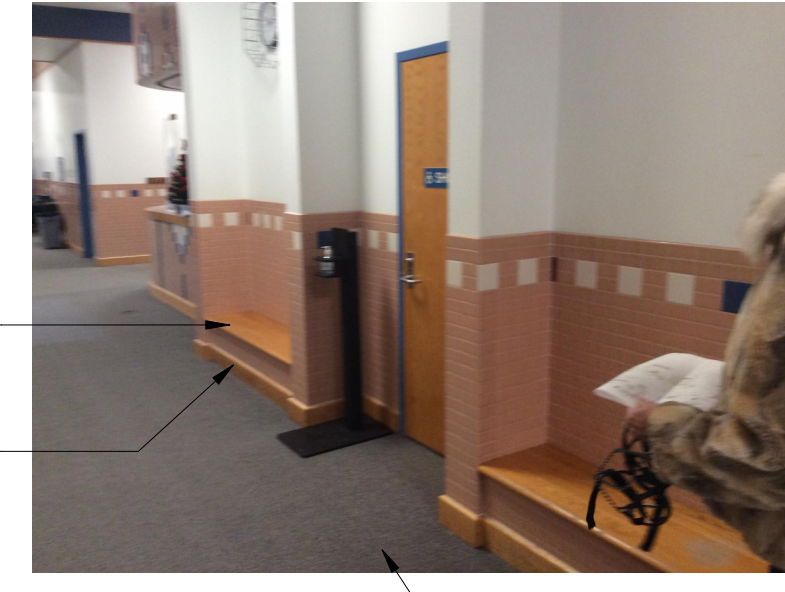

PH 7 - Corridor Benches

Remove existing carpet, underlayment and adhesive, complete.

Demolish existing casework



PH 3 - Community Room

Remove existing elevated floor tiles as required for under-floor work. Reinstall at completion.

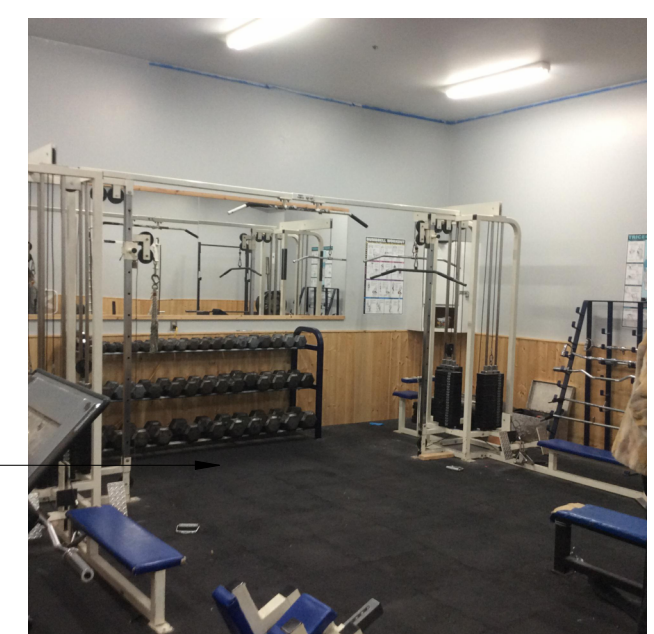

Remove existing rubber flooring tiles as required to accomplish under-floor work. Reinstall at completion

PH 14 - Weight Room



Demolish existing floor tiles, base tiles and adhesive as required to accomplish under-floor work

PH 10 - Girls Locker Room

Remove all floor mounted equipment. Reinstall at completion

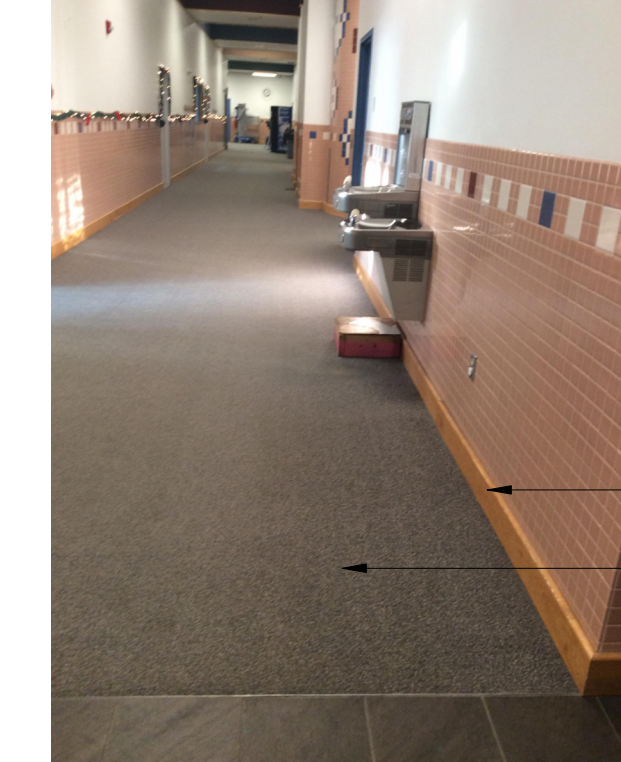

PH 6 - Corridor

Existing wood base to be removed, complete  
Existing carpet, underlayment and adhesive to be removed, complete.

Remove existing floor tile, wood base and adhesive, complete

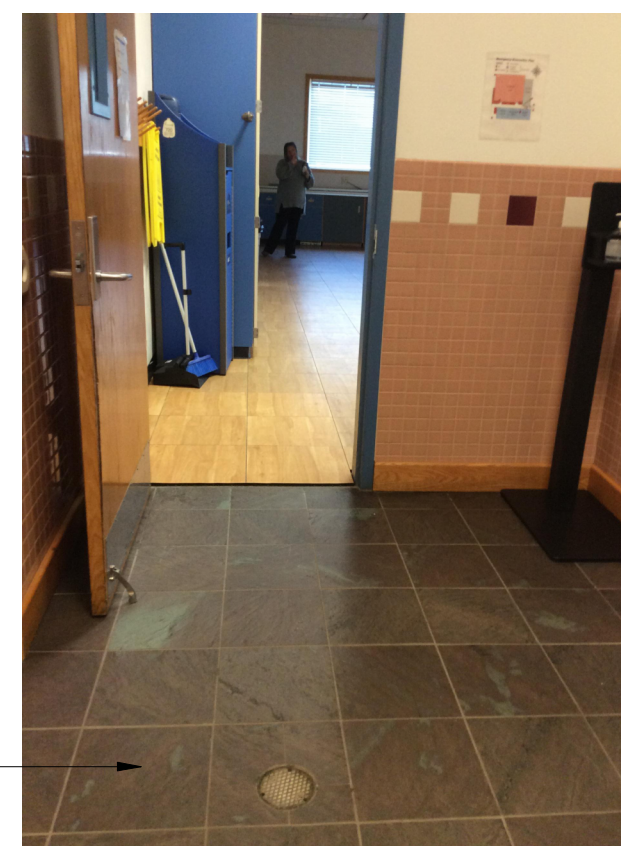

Ph 2-East Entry to Community Room

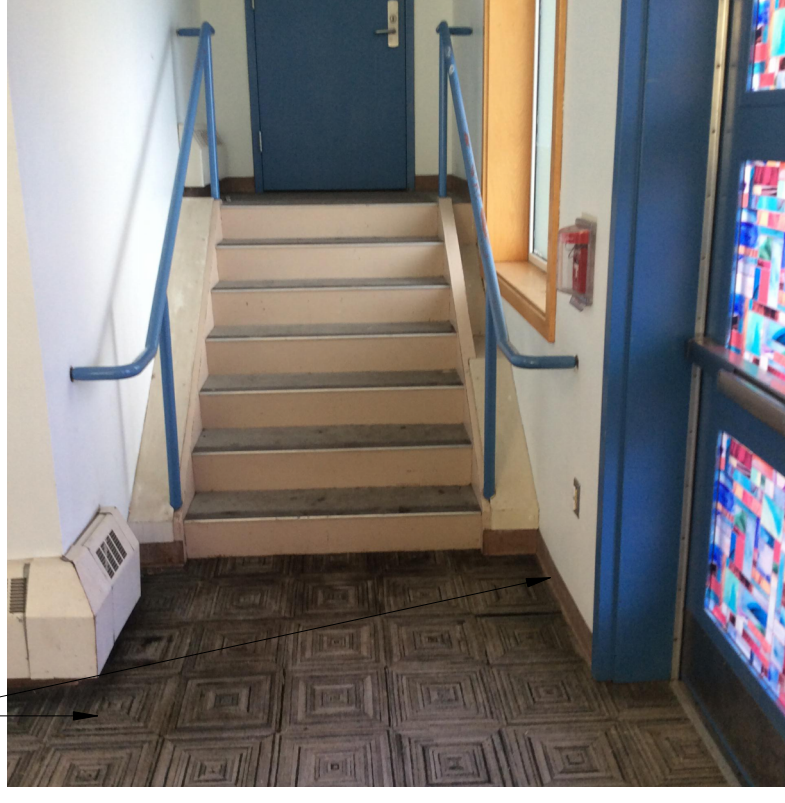

Remove existing walk-off tiles and rubber base

PH 13 - West Entry Stair

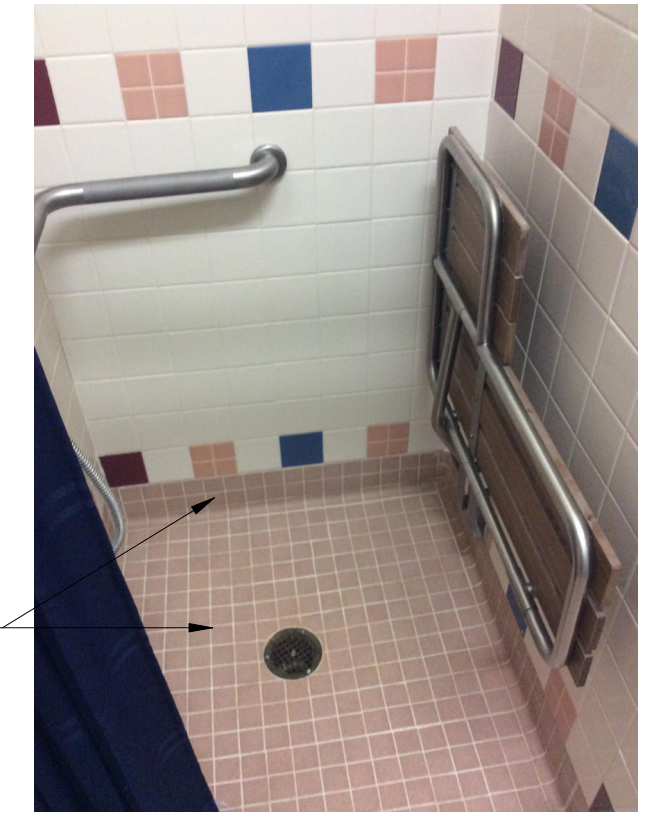

Demolish existing floor tiles, base tiles and adhesive as required to accomplish under-floor work

PH 9 - Accessible Shower



Remove existing floor tile, wood base and adhesive, complete

PH 5 - Boys Locker Room

Remove existing floor tiles at shower curb. Retain curb.

Existing floor tiles, base tiles and adhesive to be removed, complete.



Ph 1-East Entry





Hildie A. Cain, Architect  
 (907) 339-5187 hcaia@protonmail.com  
 www.hcaiaarchitecture.com

GENERAL FINISHES REPLACEMENT NOTES

1. The overall scope of work requires removal and replacement of the primary underfloor drain and branch lines.
2. Care shall be taken not to disturb existing fixtures and finishes that are scheduled to remain. If any items scheduled to remain are damaged, contractor shall replace those items with new items.
3. All floor mounted items in areas where floor finishes are to be replaced shall be removed and stored for reinstallation.
4. When branch lines must be replaced, existing floor finishes shall be removed in the entire room, complete. Sub-floor shall be patched and repaired once work is complete, and the entire sub-floor shall be prepared to accept new finishes.

Room Schedule				
Number	Name	Floor Finish	Base Finish	Comments
100	Community	Existing	-	See Note 1
101	Corridor	Carpet Tile	Wood	
102	Boys Locker	Resin	Self Cove	See Notes 2,3
103	Shower	Resin	Self Cove	See Notes 2,3
104	Accessible Restroom	Resin	Self Cove	See Notes 2,3
105	Girls Locker Room	Resin	Self Cove	See Notes 2,3
106	Boys Toilet	Resin	Self Cove	See Notes 2,3
107	Weight Room	Existing	-	See Note 1
108	Storage	Existing	-	No Work this room
109	Girls Toilet	Resin	Self Cove	See Notes 2,3
110	Vestibule	Walkoff Mat	Wood	

ROOM SCHEDULE NOTES

1. Existing flooring to be removed as required to accomplish underfloor work. Reinstall when complete.
2. Flake color(s) to be selected by Owner.
3. Evaluation of existing under-floor branch drain to be accomplished in the field prior to demolition of existing flooring and base. If branch lines need replacement, existing flooring and base to be removed in entire room, complete.
4. Patch and repair existing concrete floor after branch drain replacement.

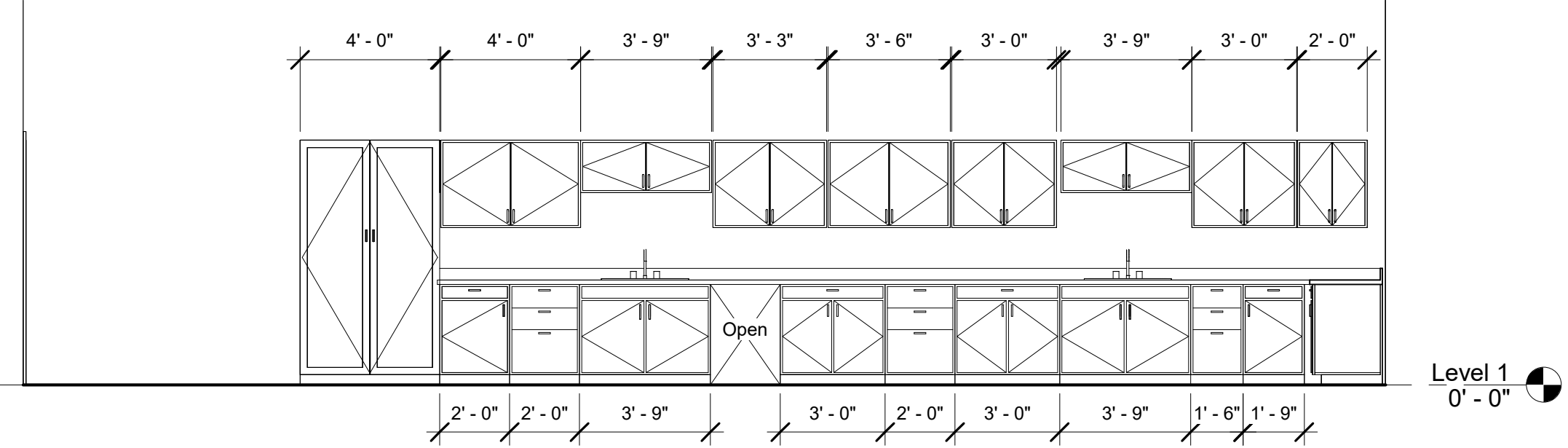

② Community Room West  
 1/4" = 1'-0"

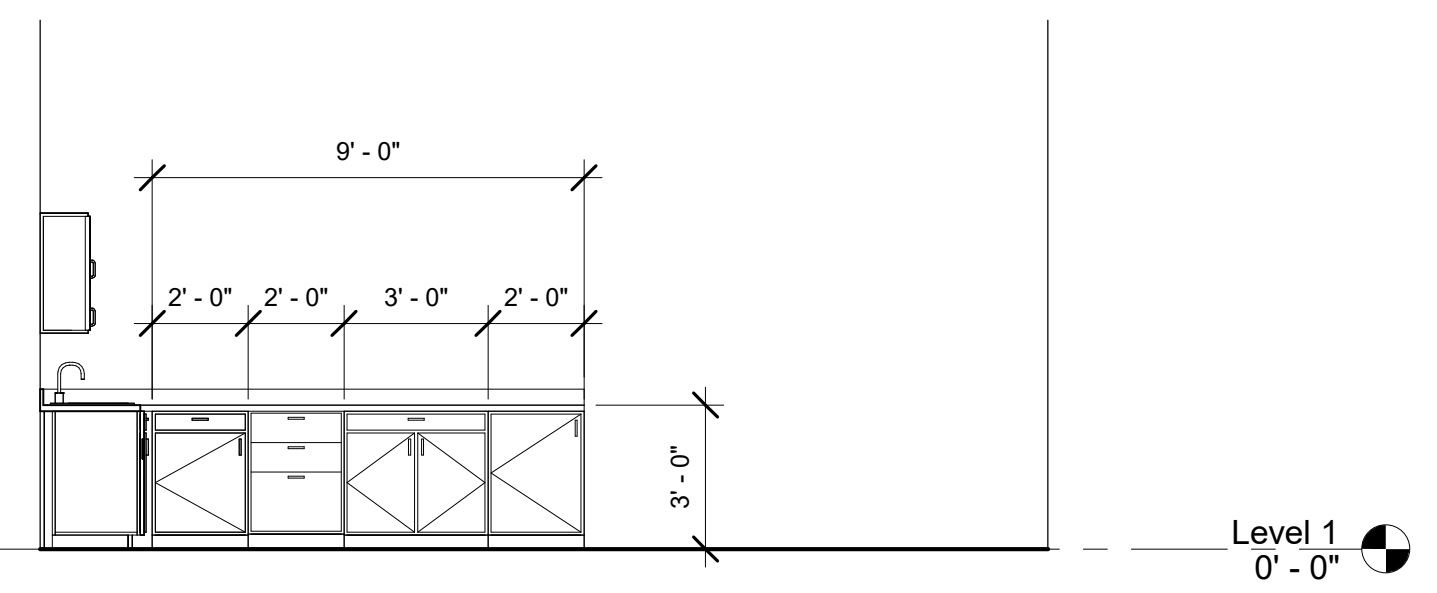

③ Community Room North  
 1/4" = 1'-0"

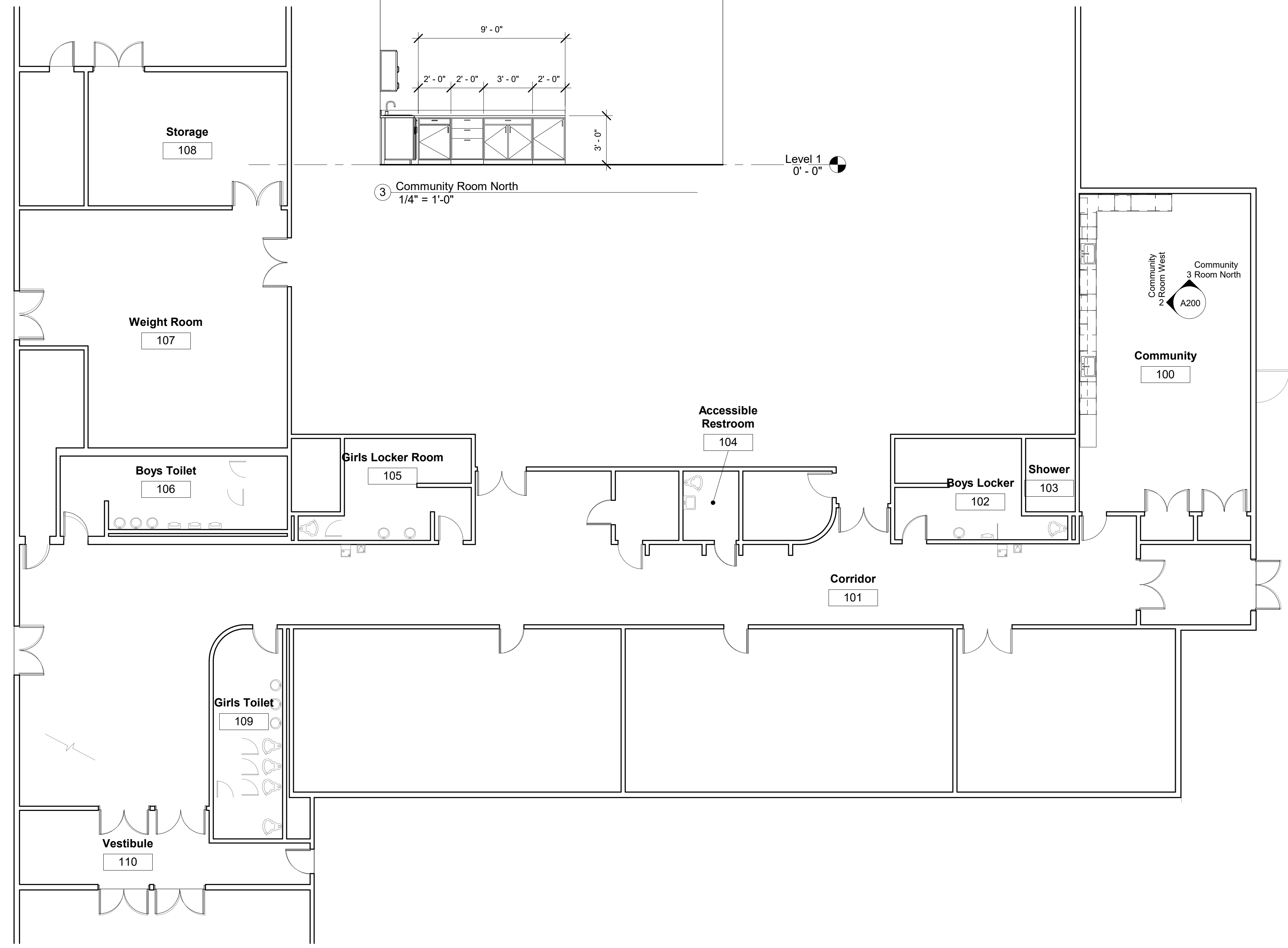

① New Work  
 1/8" = 1'-0"

PARKS & REC. WASTE PIPE REPAIR  
 PETERSBURG BOROUGH  
 500 N. 3RD. ST.  
 PETERSBURG ALASKA 99833

REVISIONS:

DRAWN BY:  
 CHECKED BY:  
 DATE: 4/7/2023  
 JOB NUMBER: 2311

DRAWING TITLE:  
 FINISH SCHEDULE,  
 DETAILS

SHEET:  
 A200



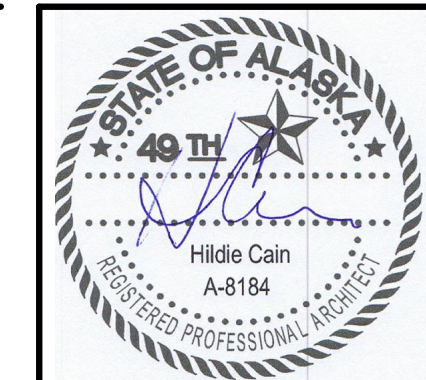

**Hilidie A. Cain, Architect**  
 (907) 739-5187 ccain@hac.com  
 www.hacarchitecture.com

**PARKS & REC. WASTE PIPE REPAIR**  
**PETERSBURG BOROUGH**  
**500 N. 3RD. ST.**  
**PETERSBURG ALASKA 99833**

REVISIONS:

DRAWN BY:  
 CHECKED BY:  
 DATE: 4/7/2023  
 JOB NUMBER: 2311

DRAWING TITLE:  
**ARCHITECTURAL SPECIFICATIONS**

SHEET:  
**A300**

**SECTION 03 54 13**  
**GYPSSUM CEMENT UNDERLAYMENT**

**PART 1 - GENERAL**

- 1.1 SUMMARY – DESIGN BASIS ARDEX LU 100
- A. Section Includes:
1. This Section includes a self-leveling underlayment that consists of a blend of high strength cements and powdered polymers used to level and smooth interior, above-grade concrete, wood, VCT, existing patching and leveling materials and non-water soluble adhesive residue on concrete.
- B. Related Sections:
1. Drawings, general provisions of the Contract, and other related construction documents such as Division 01 specifications apply to this Section.
- 1.2 REFERENCES
- A. ASTM C109M, Compressive Strength Air-Cure Only  
 B. ASTM C348, Flexural Strength of Hydraulic-Cement Mortars  
 C. ASTM F2170, Relative Humidity in Concrete Floor Slabs Using in situ Probes  
 D. ASTM F710, Standard Practice for Preparing Concrete Floors to Receive Resilient Flooring  
 E. ASTM D4263, Standard Test Method for Indicating Moisture in Concrete by the Plastic Sheet Method

- 1.4 SUBMITTALS
- A. Product Data: Submit manufacturer's product data and installation instructions for each material and product used. Include manufacturer's Safety Data Sheets.
- B. Qualification Data: For Installer
- 1.5 QUALITY ASSURANCE
- A. Installation of the ARDEX product must be completed by a factory-trained applicator, such as an ARDEX LevelMaster® Elite, Choice Contractor or INSTALL Substrate Prep Certified Installer, using mixing equipment and tools approved by the manufacturer. Please contact ARDEX Engineered Cements (724) 203-5000 for a list of recommended installers.
- B. Manufacturer Experience: Provide products of this section by companies which have successfully specialized in production of this type of work for not less than 5 years. Contact Manufacturer Representative prior to installation.

- 1.6 WARRANTY
- A. ARDEX LU 100™ installed as part of a floor system, shall be installed in conjunction with the recommended ARDEX Tile & Stone Installation Materials or WW HENRY Flooring Adhesive, as appropriate, to provide the ARDEX SystemOne 5- or 10-year comprehensive warranty, depending on the system installed.
- 1.7 DELIVERY, STORAGE AND HANDLING
- A. Deliver products in original packaging, labeled with product identification, manufacturer, batch number and shelf life.  
 B. Store products in a dry area with temperature maintained between 50° and 85°F (10° and 29°C and protect from direct sunlight.  
 C. Handle products in accordance with manufacturer's printed recommendations.

- 1.8 PROJECT CONDITIONS
- A. ARDEX LU 100™ is a gypsum-based material. Do not install in applications on or below grade or in any areas subject to high moisture conditions. Do not install material below 50°F (10°C) surface and air temperatures. These temperatures must also be maintained during and for 48 hours after the installation of products included in this section. Install quickly if substrate is warm and follow warm weather instructions available from the ARDEX Technical Service Department.

**PART 2 - PRODUCTS**

- 2.1 GYPSSUM CEMENT UNDERLAYMENT
- A. Self-leveling, gypsum-cement-based underlayment
1. Acceptable Products:
- a. ARDEX LU 100™: Manufactured by ARDEX Engineered Cements: 400 Ardex Park Drive, Aliquippa, PA, 15001, USA 724-203-5000, www.ardexamericas.com
2. Performance and Physical Properties: Meet or exceed the following values for material cured at 73° F (23° C) and 50 percent relative humidity:
- a. Primer:
- i. Standard Absorbent Concrete: ARDEX P 51™ Primer diluted 1:1 with water
- ii. Extremely Absorbent Concrete: May require two applications of ARDEX P 51 to minimize the potential for pinholes forming in the ARDEX LU 100.
- iii. Wood and Non-Water-Soluble Adhesive Residue on Concrete: ARDEX P 51™ Primer undiluted
- iv. Other Non-Porous Substrates, such as burnished concrete, terrazzo, VCT, ceramic, quarry and porcelain tiles, epoxy coating systems and concrete treated with silicate compounds: ARDEX P 82™ Ultra Prime
- b. Application: Barrel Mix or Pump  
 c. Compressive Strength: 5,000 psi (350 kg/cm2) at 28 days, ASTM C109M  
 d. Flexural Strength: 1,000 psi (70 kg/cm2) at 28 days, ASTM C348  
 e. Walkable: 2 – 3 hours  
 f. VOC: 0
- 2.2 WATER
- A. Water shall be clean, potable and sufficient cool (not warmer than 70°F).

**PART 3 – EXECUTION**

- 3.1 PREPARATION
- A. General: Prepare substrate in accordance with manufacturer's instructions.
1. Concrete Subfloors: Prepare substrate in accordance with manufacturer's instructions.
- a. Prior to proceeding please refer to ASTM F710 Standard Practice for Preparing Concrete Floors to Receive Resilient Flooring. All concrete subfloors must be sound, solid, clean, and free of all oil, grease, dirt, curing compounds and any substance that might act as a bond breaker before priming. Mechanically clean if necessary using shot blasting or other. Acid etching and use of sweeping compounds and solvents are not acceptable.

- B. Crack and Joint Preparation
1. Jointing and Moving Cracks – honor all moving joints such as expansion joints, isolation joints as well as all moving cracks up through the underlayment.

- C. Adhesive residues on concrete must first be tested to make certain they are not water-soluble. Water-soluble adhesives must be completely mechanically removed down to clean concrete. Non-water-soluble adhesives should be prepared to a thin, well-bonded residue using the wet-scraping technique as recommended by the Resilient Floor Covering Institute (www.rfci.com). The prepared residue should appear as nothing more than a transparent stain on the concrete after scraping.
- D. Non-porous subfloors such as terrazzo, burnished concrete, epoxy coating systems, VCT, ceramic quarry and porcelain tiles must be clean and free of all waxes, sealers dust, dirt, debris and any other contaminant that may act as a bond breaker. If necessary, clean by mechanical methods such as shot blasting.

**3.2 APPLICATION OF ARDEX LU100™:**

- A. Examine substrates and conditions under which materials will be installed. Do not proceed with installation until unsatisfactory conditions are corrected.
- B. Coordinate installation with adjacent work to ensure proper sequence of construction. Protect adjacent areas from contact due to mixing and handling of materials.
- C. Priming:..
1. Primer for standard absorbent concrete substrates: Dilute ARDEX P-51 1:1 with water and apply evenly with a soft bristled push broom. Do not leave any bare spots. Remove all puddles and excess primer. Allow to dry to a clear, thin film (min. 3 hours, max. 24 hours). Underlayment shall not be applied until the primer is dry. Primer coverage is approximately 400 to 600 sq. ft. per gallon.
2. Primer for extremely absorbent concrete substrates: Make an initial application of ARDEX P-51 mixed with 3 parts water using a soft push broom. Do not leave any bare spots. Remove all puddles and excess primer. Allow to dry thoroughly (1 to 3 hours) before proceeding with the standard application of primer as described above for standard absorbent concrete.
3. Primer for wood and non-water-soluble adhesive residue on concrete: Prime with undiluted ARDEX P 51. Apply directly to the prepared wood or non-water-soluble adhesive residue with a short-nap or sponge paint roller, leaving a thin coat of primer. Do not use a push broom. Do not leave any bare spots. Backroll with a dry roller to remove excess primer. Allow primer to dry to a clear, thin film (min. 3 hours, max. 24 hours).
- D. Mixing: Comply with manufacturer's printed instructions and the following.

1. Add 4 quarts (3.8 L) of clean potable water per 50 lb. (22.7 kg) bag.
2. Mix using a 1/2" (12 mm, 650 rpm) low speed heavy-duty mixing drill with an ARDEX T-1 mixing paddle. Do not overwater.
3. Aggregate mix: For areas to be installed over 2" (5 cm) thick, aggregate may be added to reduce material costs. Mix ARDEX LU 100 with water first, then add 1 part aggregate by volume of washed, well graded 1/8" to 3/8" (3 – 9.5 mm) pea gravel. Please note that the aggregate size must not exceed 1/3 the depth of the pour. Do not use sand. Note: The addition of aggregate will diminish the workability of the mix to the extent necessary to install a finish coat to obtain a smooth surface. Ardex recommends a 1/4" application of ARDEX LU 100 neat to be installed as the finish coat.
4. For pump installations, ARDEX LU 100™ shall be mixed using the ARDEX ARDIFLO™ Automatic Mixing Pumps. Contact the ARDEX Technical Service Department (888) 512-7339 for complete pump operation instructions. When installing ARDEX LU 100 with the ARDEX T-5 Smoother, install at a minimum thickness of 1/8" (3 mm) over the highest point in the floor, which typically results in an average thickness of 1/4" (6 mm) or more over the entire floor. When installing ARDEX LU 100 with the ARDEX T-6 Spiked Roller, it is possible to install a minimum thickness of 1/16" (1.5 mm) over the highest point, which typically results in an average thickness of 1/8" (3 mm). ARDEX LU 100 can be installed up to 2 inch existing elevations, ARDEX LU 100 can be tapered to as thin an application as the sand in the material will allow. If a true featheredge is needed, ARDEX recommends using ARDEX FEATHER FINISH for transitions.
5. Pour the mix onto the floor and spread with the ARDEX T-4 Spreader. Immediately smooth the material with the ARDEX T-5 Smoother, or spike roll the material with the ARDEX T-6 Spiked Roller. Work in a continuo" (5 cm) thick neat, and up to 5" (12.7 cm) with the addition of proper aggregate. To ma us manner during the entire self-leveling installation. Wear baseball or soccer shoes with non-metallic cleats to avoid leaving marks in the liquid ARDEX LU 100.

- F. Curing
1. Floor coverings can be installed after the underlayment has dried thoroughly. Allow the installation to dry a minimum of 48 hours prior to mat testing in accordance with ASTM D4263. To do this, place a piece of heavy plastic or a smooth rubber mat down over a 2' X 2' area. After 24 hours, lift the barrier material and inspect for surface darkening. A darkened area indicates excessive moisture is still present, and further drying time is required. Repeat the above test at regular intervals until no darkening is observed.
2. Once the installation is deemed dry, prime the entire area with ARDEX P 51 mixed with 3 parts water by volume. Apply the primer as outlined in the Priming section. Allow drying to a clear, thin film (min. 3 hours, max. 24 hours) before applying the thin set mortar or adhesive and floor covering. The application of ARDEX P 51 will help ensure that the adhesive or setting material has sufficient open time prior to placing the floor covering.
3. Drying time is a function of jobsite temperature and humidity conditions. While a 1/4" (6 mm) thick installation may be dry enough for some types of floor covering after only a few days, additional drying time may be necessary for deeper installations or for the installation of more moisture-sensitive flooring. Low substrate temperatures and/or high ambient humidity will extend the drying time. Adequate ventilation and heat will aid drying. Forced drying can dry the surface of the underlayment prematurely and is not recommended.

- 3.3 FIELD QUALITY CONTROL
- A. Where specified, field sampling of the Ardex underlayment is to be done by taking an entire unopened bag of the product being installed to an independent testing facility to perform compressive strength testing in accordance with ASTM C 109/modified: air-cure only. There are no in situ test procedures for the evaluation of compressive strength.

- 3.4 PROTECTION
- A. Prior to the installation of the finish flooring, the surface of the underlayment should be protected from abuse by other trades by the use of plywood, Masonite or other suitable protection course.

END OF SECTION

**SECTION 064100**  
**ARCHITECTURAL WOOD CASEWORK**

**PART 1 GENERAL**

- 1.1 SUMMARY
- A. Section Includes:
1. Special fabricated cabinet units.  
 2. Plastic laminate countertops.  
 3. Shop finishing.  
 4. Cabinet hardware.
- B. Related Sections:
1. Division 01 - Administrative, procedural, and temporary work requirements.  
 2. Section 066116 - Solid Surfacing Fabrications.  
 3. Section 079200 - Joint Sealers.  
 4. Section 123640 - Stone Countertops.
- 1.2 REFERENCES
- A. Architectural Woodwork Institute/Architectural Woodwork Manufacturers of Canada/Woodwork Institute (AWI/AWMAC/WI) - Architectural Woodwork Standards.  
 B. Association of Electrical and Medical Imaging Equipment Manufacturers (NEMA) LD-3 - High Pressure Decorative Laminates.  
 C. Forest Stewardship Council (FSC) STD-40-004 - Chain of Custody Standard.

- 1.3 SUBMITTALS
- A. Submittals for Review:
1. Shop Drawings:
- a. Include dimensioned plan, sections, elevations, and details, including interface with adjacent work.  
 b. Designate wood species and finishes.
2. Samples:
- a. 3 x 3 inch plastic laminate samples showing available colors and finishes.  
 b. Each hardware component.
- 1.4 QUALITY ASSURANCE
- A. Fabricator Qualifications:
1. Minimum 5 years documented experience in work of this Section.  
 2. Certified under AWI/AWMAC/WI Quality Certification Program.

- 1.5 DELIVERY, STORAGE AND HANDLING
- A. Do not deliver materials until proper protection can be provided, and until needed for installation.
- 1.6 PROJECT CONDITIONS
- A. Environmental Requirements: Maintain following conditions in building for minimum 7 days prior to, during, and after installation of casework:
1. Temperature: 60 to 80 degrees F.  
 2. Humidity: 17 to 50 percent.

**PART 2 PRODUCTS**

- 2.1 MANUFACTURERS
- A. Acceptable Manufacturers - Plastic Laminate:
1. Formica Corp. ([www.formica.com](http://www.formica.com))  
 2. Nevamar Co. ([www.nevamar.com](http://www.nevamar.com))  
 3. Wilsonart International, Inc. ([www.wilsonart.com](http://www.wilsonart.com))  
 4. Approved Equal.
- B. Substitutions: Under provisions of Division 01.
- 2.2 MATERIALS
- A. Sheet Products:
1. Exposed and semi-exposed veneers: Close grain hardwood, of quality suitable for opaque finish.  
 2. Sheet core: Particleboard.
- B. Lumber:
1. Graded in accordance with AWI/AWMAC/WI Architectural Woodwork Standards, Section 3 requirements for quality grade specified, average moisture content of 6 percent.  
 2. Exposed and semi-exposed locations: Close grain hardwood, of quality suitable for opaque finish.
- C. Hardboard: Pressed wood fiber with resin binder; standard grade, 1/4 inch thick, smooth one side.

- D. Plastic Laminate: NEMA LD-3.
1. High pressure decorative laminate:
- a. Horizontal surfaces:
- 1) Backing sheet: Grade BGF.  
 2) Postformed surfaces: Grade HGP.  
 3) Acid resisting: Grade LGP.  
 4) Other surfaces: Grade HGS.
- b. Vertical surfaces:
- 1) Backing sheet: Grade BLF.  
 2) Cabinet liner: Grade CLS.  
 3) Other surfaces: Grade VGP.
2. Low pressure decorative laminate: Grade VGL.  
 3. Colors: To be selected from manufacturer's full color range.  
 4. Finish: Matte.

- 2.3 ACCESSORIES
- A. Fasteners: Type and size as required by conditions of use.
- B. Adhesives:
1. Waterproof, water based type, compatible with backing and laminate materials.
- C. Finish Hardware: As scheduled at end of Section [or approved substitute].
- D. Joint Sealers: Specified in Section 079200.

- 2.4 FABRICATION
- A. Cabinets - Plastic Laminate Finish:
1. Quality: AWI/AWMAC/WI Architectural Woodwork Standards, Section 10, Custom Grade.  
 2. Construction type: Frameless.  
 3. Interface style: Overlay.

4. Semi-exposed surfaces: High pressure decorative laminate.  
 5. Fit exposed and semi-exposed sheet edges with matching PVC edging.  
 6. Fabricate drawer bodies to full depth of drawer fronts less 1/2 inch.
- B. Plastic Laminate Countertops:
1. Quality: AWI/AWMAC/WI Architectural Woodwork Standards, Section 11, Custom Grade.  
 2. Fabricate from sheet product with lumber fronts.  
 3. Locate end joints centered or symmetrical. Join sections with concealed clamp fasteners. Locate plastic laminate butt joints minimum 2 feet away from sinks.  
 4. Provide holes and cutouts for mounting of sinks, trim, and accessories.
- C. Shop assemble for delivery to project site in units easily handled.
- D. Prior to fabrication, field verify dimensions to ensure correct fit.
- E. Apply plastic laminate in full uninterrupted sheets; fit corners and joints to hairline. Slightly bevel arises. Apply laminate backing sheet to reverse side of laminate faced surfaces.
- F. Where field fitting is required, provide ample allowance for cutting. Provide trim for scribing and site conditions.
- G. Provide cutouts and reinforcement for [plumbing,] [electrical,] [appliances,] [and] [accessories]. Prime paint surfaces of cut edges.

- 2.5 FINISHES
- A. Factory Finishing:
1. Factory finish casework in accordance with AWI/AWMAC/WI Architectural Woodwork Standards, Section 5.  
 2. Finish system: Polyurethane, Water-based.  
 3. Color: To be selected from manufacturer's full color range.  
 4. Sheen: Satin.

**PART 3 EXECUTION**

- 3.1 PREPARATION
- A. Prior to installation, condition cabinets to average humidity that will prevail after installation.
- 3.2 INSTALLATION
- A. Install in accordance with AWI/AWMAC/WI Architectural Woodwork Standards.  
 B. Set plumb, rigid and level.  
 C. Scribe to adjacent construction with maximum 1/8 inch gaps.  
 D. Adhere countertops, splashes, and skirts with beads of adhesive.  
 E. Fill joints between cabinets, tops, splashes, and adjacent construction with joint sealer as specified in Section 079200; finish flush.

END OF SECTION

**SECTION 064600**  
**WOOD TRIM**

**PART 1 GENERAL**

- 1.1 SUMMARY
- A. Section Includes:
1. Interior wood trim.  
 2. Shop finishing.
- B. Related Sections:
1. Division 01: Administrative, procedural, and temporary work requirements.

- 1.2 REFERENCES
- A. American Wood Protection Association (AWPA) U1 - Use Category System - User Specification for Treated Wood.  
 B. Architectural Woodwork Institute/Architectural Woodwork Manufacturers of Canada/Woodwork Institute (AWI/AWMAC/WI) - Architectural Woodwork Standards.  
 C. ASTM International (ASTM) E84 - Standard Test Method for Surface Burning Characteristics of Materials.  
 D. Forest Stewardship Council (FSC) STD-40-004 - Chain of Custody Standard.

- 1.3 SUBMITTALS
- A. Submittals for Review:
1. Shop Drawings:
- a. Include dimensioned plans, sections, elevations, and details, including interface with adjacent work.  
 b. Designate wood species and finishes.
2. Samples: 6 inch long samples of each profile.

- 1.4 QUALITY ASSURANCE
- A. Fabricator Qualifications:
1. Minimum 5 years documented experience in work of this Section.  
 2. Certified under AWI/AWMAC/WI Quality Certification Program.
- 1.5 DELIVERY, STORAGE AND HANDLING
- A. Do not deliver materials until proper protection can be provided, and until needed for installation.

- 1.6 PROJECT CONDITIONS
- A. Environmental Requirements: Maintain following conditions in building for minimum 7 days prior to, during, and after installation of interior trim:
1. Temperature: 60 to 80 degrees F.  
 2. Humidity: 17 to 50 percent.

**PART 2 PRODUCTS**

- 2.1 MANUFACTURERS
- A. Acceptable Manufacturers:



- 1. To be selected.
- 2.2 MATERIALS
  - A. Interior Trim:
    - 1. Graded in accordance with AWI/AWMAC/WI Architectural Woodwork Standards, Section 3 requirements for quality grade specified, average moisture content of 6 percent.
  - 2. Close grain hardwood, of quality suitable for opaque finish.
- 2.3 ACCESSORIES
  - A. Fasteners: Type and size as required by conditions of use; plain steel for interior use; hot dip galvanized steel for exterior use.
  - B. Adhesives:
    - 1. Waterproof, water based type, compatible with trim and substrate materials.
- 2.4 FABRICATION
  - A. Quality: AWI/AWMAC/WI Architectural Woodwork Standards, Section 6, Custom Grade.
  - B. Where field fitting is required, provide ample allowance for cutting.
  - C. Groove back of trim applied to flat substrate, except do not groove exposed ends.
- 2.5 FINISHES
  - A. Factory Finishing:
    - 1. Factory finish interior trim in accordance with AWI/AWMAC/WI Architectural Woodwork Standards, Section 5.
    - 2. Finish system: Polyurethane, Water-based.
    - 3. Color: To be selected from manufacturer's full color range.
    - 4. Sheen: Satin.

**PART 3 EXECUTION**

- 3.1 PREPARATION
  - A. Prior to installation, condition wood to average humidity that will prevail after installation.
  - B. Back prime wood installed against cementitious materials prior to installation.
- 3.2 INSTALLATION
  - A. Install in accordance with AWI/AWMAC/WI Architectural Woodwork Standards.
  - B. Install in longest practical lengths.
  - C. Set plumb and level.
  - D. Miter ends, corners, and intersections.
  - E. Scribe to adjacent construction with maximum 1/8 inch gaps.
  - F. Fasten to supporting construction.

END OF SECTION

**SECTION 096723 – RESINOUS FLOORING**

**PART 1 - GENERAL**

- 1.1 SUMMARY
  - A. This Section includes:
    - 1. High-performance resinous flooring systems.
- 1.2 SUBMITTALS
  - A. Product Data: For each type of product indicated.
  - B. Installer Certificates for Qualification: Signed by manufacturer stating that installers comply with specified requirements.
  - C. Material Certificates: For each resinous flooring component, from manufacturer.
  - D. Maintenance Data: For maintenance manuals.
  - E. Samples: Submit two 6" X 6" samples of each resinous flooring system applied to a rigid backing. Provide sample which is a true representation of proposed field applied finish. Provide sample color and texture for approval from Owner in writing or approved by General Contractor prior to installation.
  - F. Product Schedule: For resinous flooring.
- 1.3 QUALITY ASSURANCE
  - A. Installer Qualifications: Manufacturer's authorized representative who is trained and approved for installation of flooring systems required for this Project.
    - 1. Engage an installer who is approved in writing by resinous flooring manufacturer as qualified to apply resinous flooring systems indicated.
    - 2. Installer Letter of Qualification: Installer to provide letter stating that they have been in business for at least 5 years and listing 5 projects in the last 2 years of similar scope. For each project provide: project name, location, date of installation, contact information, size of project, and manufacturer of materials with system information.
  - B. Source Limitations: Obtain primary resinous flooring materials, including primers, resins, hardening agents, grouting coats, and topcoats, from single source from single manufacturer. Provide secondary materials, including patching and fill material, joint sealant, and repair materials, of type and from source recommended by manufacturer of primary materials.
  - C. Pre-installation Conference: Conduct conference at Project site before work and mockups begin.
  - D. Mockups: Apply mockups to verify selections made under sample submittals and to demonstrate aesthetic effects and set quality standards for materials and execution. Do not cover up mockup area.
    - 1. Apply full-thickness mockups on 16 square foot floor area selected by Architect.
    - 2. Finish surfaces for verification of products, color, texture, and sheen.
    - 3. Simulate finished lighting conditions for Architect's review of mockups.
    - 4. Approved mockups may become part of the completed Work if undisturbed at time of Substantial Completion.
    - 5. Mockup shall demonstrate desired slip resistance for review and approval by Owner's representative in writing.
- 1.4 DELIVERY, STORAGE, AND HANDLING
  - A. Deliver materials in original packages and containers, with seals unbroken, bearing manufacturer's labels indicating brand name and directions for storage and mixing with other components.
    - 1. Maintain containers in clean condition, free of foreign materials and residue.
    - 2. Remove rags and waste from storage areas daily.

**1.5 PROJECT CONDITIONS**

- A. Environmental Limitations: Comply with resinous flooring manufacturer's written instructions for substrate temperature, ambient temperature, moisture, ventilation, and other conditions affecting resinous flooring application.
- B. Lighting: Provide permanent lighting or, if permanent lighting is not in place, simulate permanent lighting conditions during resinous flooring application.
- C. Close spaces to traffic during resinous flooring application and for not less than 24 hours after application unless manufacturer recommends a longer period.

**PART 2 - PRODUCTS**

- 2.1 MANUFACTURERS
  - A. Manufacturers: Design Basis: Subject to compliance with requirements, provide products by:
    - 1. The Sherwin Williams Company, Cleveland, OH. Representative Contact: Michael Starner (484) 624-2360 [michael.starner@sherwin.com](mailto:michael.starner@sherwin.com).
  - B. Resufloor Screed Deco Flake, 3/16" – 1/4" nominal thickness.
    - 1. Primer: Resufloor 3579 at 250 sq. ft. per gallon.
    - 2. Mortar at 3/16": Resufloor 3561 with 5115 70 lbs. per 1.25 gallons resin spread at 44 sq. ft. per kit.
    - 3. Bonding Coat: Resufloor 3746 at 100 sq. ft. per gallon.
    - 4. Broadcast: Colored Flake 6750DB/6755DB to excess at 200 lbs. per 1,000 sq. ft.
    - 5. Seal Coat: Resufloor 3746 at 100 sq. ft. per gallon.
- 2.2 MATERIALS
  - A. VOC Content of Resinous Flooring: Provide resinous flooring systems, for use inside the weatherproofing system, that comply with the following limits for VOC content when calculated according to 40 CFR 59, Subpart D (EPA Method 24J).
    - 1. Resinous Flooring: 100 g/L.
- 2.3 HIGH-PERFORMANCE RESINOUS FLOORING
  - A. Resinous Flooring: Abrasion-, impact- and chemical-resistant, high-performance, resin-based, monolithic floor surfacing designed to produce a seamless floor.
  - B. System Characteristics:
    - 1. Color and Pattern: As indicated from manufacturers listed above.
    - 2. Slip Resistance: Provide slip resistant finish.

**PART 3 - EXECUTION**

- 3.1 PREPARATION
  - A. Inspection: Prior to commencing Work, thoroughly examine all underlying and adjoining work, surfaces and conditions upon which Work is in any way dependent for perfect results. Report all conditions which affect Work. No "waiver of responsibility" for incomplete, inadequate or defective underlying and adjoining work, surfaces and conditions will be considered, unless notice of such unsatisfactory conditions has been filed and agreed to in writing before Work begins. Commencement of Work constitutes acceptance of surfaces.
  - B. Surface Preparation: Remove all surface contamination, loose or weakly adherent particles, laitance, grease, oil, curing compounds, paint, dust and debris by blast track method or approved mechanical means (acid etch not allowed). If surface is questionable try a test patch. Create a minimum surface profile for the system specified in accordance with the methods described in ICR No. 03732 to achieve profile numbers as follows:
    - C.
      - 1. Thin film, to 10 mils CSP-1 to CSP-3
      - 2. Thin and medium films, 10 to 40 mils CSP-3 to CSP-5
      - 3. Self-leveling mortars, to 3/16" CSP-4 to CSP-6
      - 4. Mortars and laminates, to 1/4" or more CSP-5 to CSP-10
    - D. Verify that concrete substrates are dry and moisture-vapor emissions are within acceptable levels according to manufacturer's written instructions.
      - 1. Moisture Testing: Perform tests indicated below.
        - a. Calcium Chloride Test: Perform anhydrous calcium chloride test per ASTM F 1869. Proceed with installation only after substrates have maximum moisture-vapor-emission rate of 3 lb of water/1000 sq. ft. in 24 hours. Perform tests so that each test area does not exceed 1000 sq. ft. and perform 3 tests for the first 1000 sq. ft. and one additional test for every additional 1000 sq. ft.
        - b. In-Situ Probe Test: Perform relative-humidity test using in-situ probes per ASTM F 2170. Proceed with installation only after substrates have a maximum 75 percent relative-humidity-level measurement.
- 3.2 ENVIRONMENTAL CONDITIONS
  - A. All applicators and all other personnel in the area of the RF installation shall take all required and necessary safety precautions. All manufacturers' installation instructions shall be implicitly followed.
  - B. Repair damaged and deteriorated concrete according to resinous flooring manufacturer's written instructions.
  - C. Alkalinity and Adhesion Testing: Verify that concrete substrates have pH within acceptable range. Perform tests recommended by manufacturer. Proceed with application only after substrates pass testing.
  - D. Resinous Materials: Mix components and prepare materials according to resinous flooring manufacturer's written instructions.
  - E. Use patching and fill material to fill holes and depressions in substrates according to manufacturer's written instructions.
  - F. Treat control joints and other nonmoving substrate cracks to prevent cracks from reflecting through resinous flooring according to manufacturer's written instructions.
- 3.3 APPLICATIONS
  - A. Install resinous floor over properly prepared concrete surface in strict accordance with the manufacturer's directions.
    - 1. Install the primer and/or base coats over thoroughly cleaned and prepared concrete.
    - 2. Install topcoat over flooring after excess aggregate has been removed.
    - 3. Maintain a slab temperature of 60°F to 80°F for 24 hours minimum before applying floor topping, or as instructed by manufacturer.
  - B. Apply components of resinous flooring system according to manufacturer's written instructions to produce a uniform, monolithic wearing surface of thickness indicated.
    - 1. Coordinate application of components to provide optimum adhesion of resinous flooring system to substrate, and optimum intercoat adhesion.
    - 2. Cure resinous flooring components according to manufacturer's written instructions. Prevent contamination during application and curing processes.
    - 3. At substrate expansion and isolation joints, comply with resinous flooring manufacturer's written instructions.
  - C. Sealant: Saw cut resinous floor topping at expansion joints in concrete slab. Fill sawcuts with sealant prior to final seal coat application. Follow manufacturer's written recommendations.
  - D. Apply primer over prepared substrate at manufacturer's recommended spreading rate.
  - E. Slip Resistant Finish: Provide grit for slip resistance.
  - F. Apply topcoats in number indicated for flooring system and at spreading rates recommended in writing by manufacturer.

**3.4 COMPLETED WORK**

- A. Cleaning: Upon completion of the Work, clean up and remove from the premises surplus materials, tools, appliances, empty cans, cartons and rubbish resulting from the Work. Clean up all spattering and drippings, and all resulting stains.
- B. Protection: Protect Work in accordance with manufacturer's directions from damage and wear during the remainder of the construction period. Use protective methods and materials, including temporary covering, recommended in writing by resinous flooring manufacturer.
- C. Contractor shall insure that coating is protected from any traffic until it is fully cured to the satisfaction of the coating manufacturer.

END OF SECTION

**SECTION 096813  
TILE CARPETING**

**GENERAL**

- 1.1 SUMMARY
  - A. Section Includes:
    - 1. Tile carpeting.
    - 2. Edgings.
  - B. Related Sections:
    - 1. Division 01: Administrative, procedural, and temporary work requirements.
- 1.2 REFERENCES
  - A. ASTM International (ASTM):
    - 1. D2859 - Standard Test Method for Flammability of Finished Textile Floor Covering Materials.
    - 2. D4258 - Standard Practice for Surface Cleaning Concrete for Coating.
    - 3. E84 - Standard Test Method for Surface Burning Characteristics of Building Materials.
    - 4. E648 - Standard Test Method for Critical Radiant Flux of Floor Covering Systems Using a Radiant Heat Energy Source.
    - 5. E662 - Standard Test Method for Specific Optical Density of Smoke Generated by Solid Materials.
    - 6. F710 - Standard Practice for Preparing Concrete to Receive Resilient Flooring.
    - 7. F1869 - Standard Test Method for Measuring Moisture Vapor Emission Rate of Concrete Subfloor Using Anhydrous Calcium Chloride.
    - 8. F2170 - Standard Test Method for Determining Relative Humidity in Concrete Floor Slabs Using in situ Probes.
  - B. Carpet and Rug Institute (CRI):
    - 1. 104 - Standard for Installation Specification of Commercial Carpet.
    - 2. Indoor Air Quality Testing Program.
  - C. National Fire Protection Association (NFPA) 253 - Test for Critical Radiant Flux of Floor Covering Systems Using a Radiant Heat Energy Source.
- 1.3 SUBMITTALS
  - A. Submittals for Review:
    - 1. Shop Drawings: Indicate carpet tile locations, dye lot limitations, direction of carpet tile in each room or area, and type and location of edgings.
    - 2. Samples:
      - a. Carpet tile: Full size samples in each color and pattern.
      - b. Edgings: 4 inch long samples showing available colors.
    - 3. Warranty: Sample warranty form.
  - B. Quality Control Submittals:
    - 1. Certificates of Compliance: Certification from an independent testing laboratory that carpet tiles meet fire hazard classification requirements.
- 1.4 QUALITY ASSURANCE
  - A. Installer Qualifications: Minimum two years documented experience in work of this Section.
  - B. Fire Hazard Classification: Class I rated, tested to ASTM E648.
  - C. Mockup:
    - 1. Size: Minimum 12 x 12 feet.
    - 2. Show: Carpet tile color and pattern, and edgings.
    - 3. Locate where directed.
    - 4. Approved mockup may not remain as part of the Work.
- 1.5 PROJECT CONDITIONS
  - A. Do not begin installation until painting and finishing work have been completed.
  - B. Environmental Requirements:
    - 1. Temperature of spaces and subfloor between 65 and 90 degrees F.
    - 2. Humidity in spaces to receive carpet tiles between 20 and 65 percent.
- 1.6 WARRANTIES
  - A. Furnish installer's one year warranty providing coverage against:
    - 1. Defective materials and workmanship.
    - 2. Excessive fading.
    - 3. Loss of static control.
    - 4. Edge raveling.
    - 5. Runs.
    - 6. Loss of tuft bind strength.
    - 7. Loss of face fiber.
    - 8. Excessive wear.
- 1.7 MAINTENANCE
  - A. Extra Materials: Two unopened cartons of each tile.

**PART 2 PRODUCTS**

- 2.1 MANUFACTURERS
  - A. Acceptable Manufacturers - Carpet Tiles:
    - 1. Interface, Inc. ([www.interfaceinc.com](http://www.interfaceinc.com))
    - 2. Mohawk International ([www.mohawkinternational.com](http://www.mohawkinternational.com))
    - 3. Shaw. ([www.shawcontract.com](http://www.shawcontract.com))
    - 4. Approved Equal.
  - B. Substitutions: Under provisions of Division 01.
- 2.2 MATERIALS
  - A. Carpet Tiles:
    - 1. Source: To Be Selected.
    - 2. Pattern: To Be Selected.
    - 3. Color: To Be Selected.
    - 4. Construction: Multi level loop.
    - 5. Face yarn type: Nylon.
    - 6. Face yarn weight: 40 ounces per square yard.
    - 7. Backing: Unitary.
    - 8. Total Density: Minimum 3100.
    - 9. Size: To Be Selected.
- 2.3 ACCESSORIES
  - A. Adhesive:
    - 1. Waterproof, latex based cement formulated specifically for installing carpet tiles; recommended by carpet tile manufacturer.
  - B. Edgings: Preformed rubber, profile required to suit conditions, color to be selected from manufacturer's full color range.

**PART 3 EXECUTION**

- 3.1 EXAMINATION
  - A. Verify that concrete floors have cured a minimum 28 days and do not exhibit negative alkalinity, carbonization, or dusting.
- 3.2 PREPARATION
  - A. Clean substrate; remove loose and foreign matter that could impede adhesion or performance of flooring.
  - B. Fill cracks, voids, and depressions with leveling compound.
  - C. Grind ridges and high spots smooth.
  - D. Test Substrate:
    - 1. Moisture vapor: Test to ASTM F1869; do not install carpet tiles until moisture emission level is acceptable to carpet tile manufacturer.
    - 2. Humidity: Test to ASTM F2170; do not install carpet tiles until relative humidity is acceptable to carpet tile manufacturer.
    - 3. Alkalinity: Test to ASTM F710; do not install carpet tiles unless pH is acceptable to carpet tile manufacturer.
- 3.3 INSTALLATION OF CARPET TILES
  - A. Install in accordance with CRI 104.
  - B. Install carpet tile and adhesive in accordance with manufacturers' instructions.
  - C. Blend carpet tiles from different cartons to ensure minimal variation in color match.
  - D. Lay out each room or area to minimize tiles less than one half size.
  - E. Cut tile clean. Fit tiles tight to intersection with vertical surfaces without gaps.
  - F. Lay carpet tile to manufacturer's recommended pattern, with tile direction as selected to next unit, set parallel to building lines.
  - G. Locate change of color or pattern between rooms under door centerline.
  - H. Fully adhere carpet tiles to substrate.
  - I. Adhere tiles in one row in each direction at 30 feet on center maximum. Adhere perimeter and cut tiles. Lay remaining tiles loose.
  - J. Bind cut edges where not concealed by edge strips.
- 3.4 INSTALLATION OF EDGINGS
  - A. Install strips where carpet tiles abut dissimilar flooring materials; secure to subfloor.
  - B. Center strips under doors where carpet tiles terminate at door openings.
  - C. Install in longest practical lengths; but ends tight.
  - D. Scribe to abutting surfaces.
- 3.5 CLEANING
  - A. Clean spots as recommended by carpet tile manufacturer.
  - B. Cut off loose threads flush with top surface.
  - C. Clean with commercial vacuum cleaner.

END OF SECTION

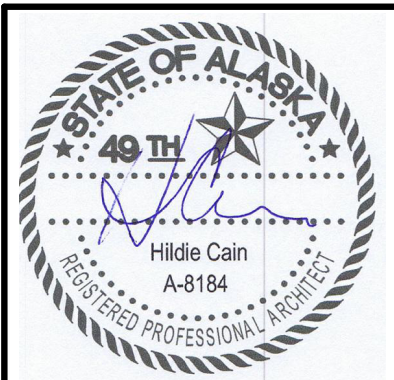

**PARKS & REC. WASTE PIPE REPAIR**  
**PETERSBURG BOROUGH**  
**500 N. 3RD. ST.**  
**PETERSBURG ALASKA 99833**

REVISIONS:

DRAWN BY:  
 CHECKED BY:  
 DATE: 4/7/2023  
 JOB NUMBER: 2311

DRAWING TITLE:  
**ARCHITECTURAL SPECIFICATIONS**

SHEET:  
**A301**





ENGINEERS, INC.  
 9560 Glacier Highway, Ste. 100  
 Juneau, Alaska 99801  
 Phone: 907.586.2093  
 Fax: 907.586.2099  
 PND# 222128

PARKS & REC. WASTE PIPE REPAIR  
 PETERSBURG BOROUGH  
 500 N. 3RD. ST.  
 PETERSBURG ALASKA 99833

REVISIONS:

DRAWN BY: PJD  
 CHECKED BY: MDS  
 DATE: 4/7/2023  
 JOB NUMBER: M2219.00  
 DWG FILE: MSERIES

DRAWING TITLE:  
 STRUCTURAL GENERAL  
 NOTES, PLAN & DETAIL

SHEET:  
 S100

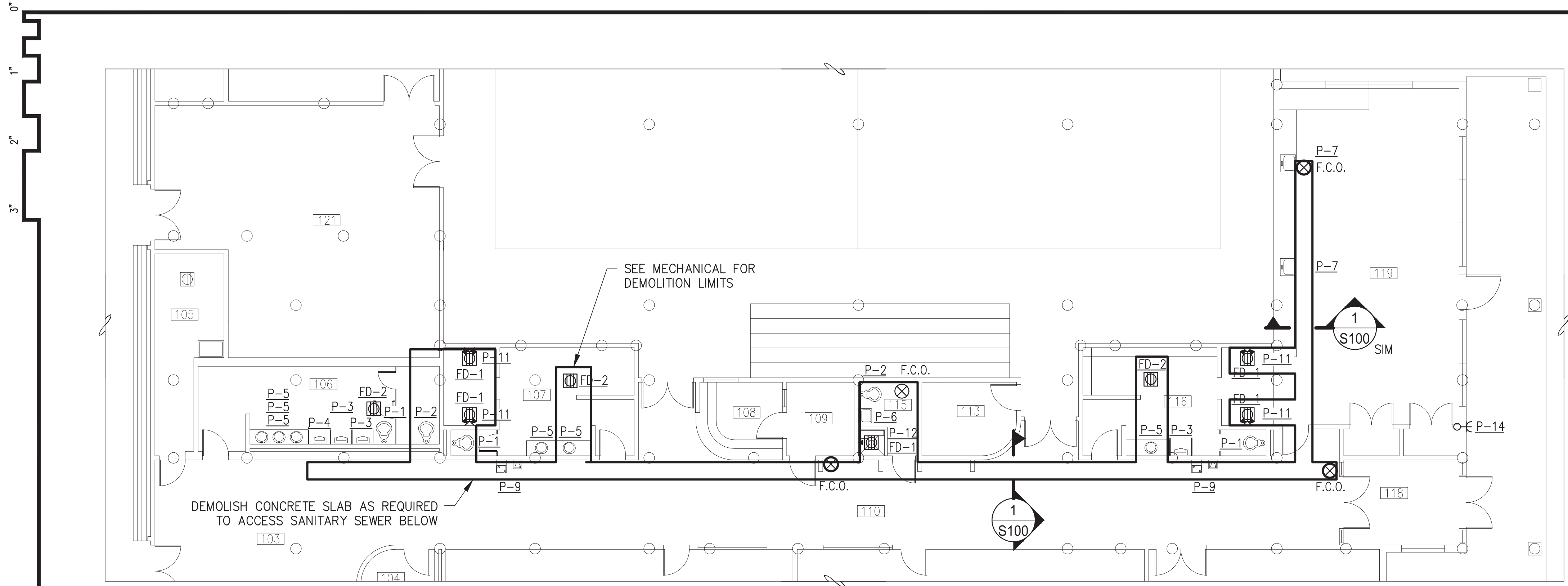

**1 SLAB MODIFICATION PLAN**  
 1/8" = 1'-0"

**GENERAL NOTES**

**CRITERIA**  
 2012 EDITION OF INTERNATIONAL BUILDING CODE (IBC) AS AMENDED BY THE STATE OF ALASKA AND CITY AND BOROUGH OF PETERSBURG

STRUCTURAL RISK CATEGORY: II

**LOADS:**  
 LIVE LOAD = 100 PSF

**FOUNDATION**  
 FOUNDATION HAS BEEN DESIGNED FOR AN ALLOWABLE SOIL PRESSURE OF 1500 PSF BASED UPON THE ASSUMPTION OF ENCOUNTERING TYPE 4 SOILS AS DEFINED IN TABLE 1806.2 OF THE IBC. CONTRACTOR SHALL VERIFY CONDITIONS AT THE LIMIT OF EXCAVATION AND REPORT TO ENGINEER.

**MATERIALS AND CONSTRUCTION**

**BASE COURSE**  
 BASE COURSE SHALL BE WELL-GRADED SANDS AND GRAVELS WITH MINIMUM SILT. PLACE BASE COURSE IN LIFTS NO GREATER THAN 6 INCHES IN LOOSE THICKNESS AND COMPACT WITH A MINIMUM LEVEL OF EFFORT OF 6 PASSES WITH A WALK-BEHIND VIBRATORY PLATE COMPACTOR WITH A MINIMUM RATED FORCE LEVEL OF 14,000 POUNDS.

**FILL**  
 FILL SHALL BE WELL-GRADED SANDS AND GRAVELS WITH LESS THAN 6% FINES. PLACE FILL IN LIFTS NO GREATER THAN TWICE THE DIAMETER OF THE LARGEST PARTICAL OR 6 INCHES OF LOOSE THICKNESS AND COMPACT WITH A MINIMUM LEVEL OF EFFORT OF 6 PASSES WITH A WALK-BEHIND VIBRATORY PLATE COMPACTOR WITH A MINIMUM RATED FORCE LEVEL OF 14,000 LBS.

**CONCRETE**  
 MIXING, PLACING, AND CURING OF CONCRETE AND SELECTION OF MATERIALS SHALL BE IN ACCORDANCE WITH THE IBC. PROPORTIONS OF AGGREGATE, CEMENT AND WATER SHALL BE SUCH TO RESULT IN A DENSE WORKABLE MIX WHICH CAN BE PLACED WITHOUT EXCESS SURFACE WATER. A MIX DESIGN, WITH RECORDED CYLINDER TEST RESULTS SHALL BE SUBMITTED FOR REVIEW AND APPROVAL PRIOR TO MOBILIZING CONCRETE EQUIPMENT TO THE SITE. MAXIMUM SLUMP SHALL BE 4 INCHES PRIOR TO ADDING PLASTICISERS OR WATER REDUCERS ON SITE. 28-DAY COMPRESSIVE STRENGTH ( $f_c'$ ) SHALL BE 4,000 PSI.

CONCRETE REINFORCING SHALL COMPLY WITH ASTM A705 GRADE 60. LAP REINFORCING STEEL 50 BAR DIAMETERS UNLESS OTHERWISE NOTED. AT CORNERS ADD CORNER BARS AT EACH HORIZONTAL BARS WITH LEG LENGTH AT LEAST 50 DIAMETER LAP LENGTH OR EXTEND THE HORIZONTAL BARS WITH A 90 DEGREE HOOK WITH A 50 DIAMETER LAP LENGTH.

REINFORCING SHALL BE SUPPORTED AND SECURED IN PLACE PRIOR TO CONCRETE PLACEMENT USING WELL-CURED CONCRETE BLOCKS OR APPROVED STEEL CHAIRS. WELDING OF REINFORCING IS PROHIBITED UNLESS SPECIFICALLY NOTED.

PROVIDE MINIMUM COVER AT REINFORCING BARS AS FOLLOWS: CAST AGAINST EARTH 3 INCHES, EXPOSED TO EARTH OR WEATHER 2 INCHES.

**ANCHOR EPOXY**  
 ANCHOR EPOXY SHALL BE HILTI HIT-RE 500, PREPARE HOLE AND INSTALL PER MANUFACTURER'S INSTRUCTIONS.

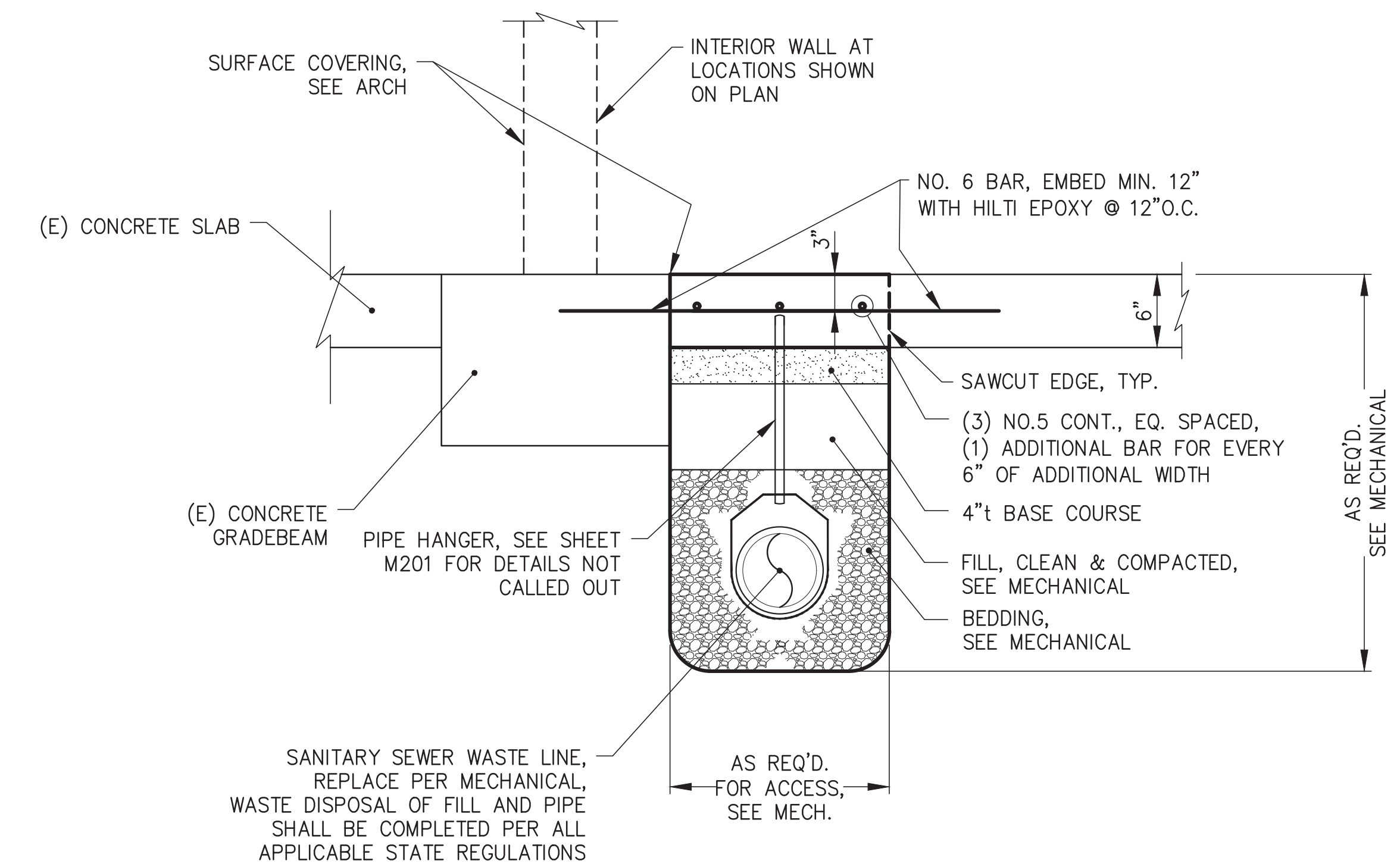

**1 TYPICAL TRENCH DETAIL**  
 NOT TO SCALE





**RSA**  
**Engineering, Inc.**  
 MECHANICAL AND ELECTRICAL CONSULTING ENGINEERS  
 670 West Friedland Lane, Suite 200  
 Anchorage, AK 99503  
 Phone (907) 276-0521  
 Corporate No.: AECC542

**PARKS & REC. WASTE PIPE REPAIR**  
**PETERSBURG BOROUGH**  
**500 N. 3RD. ST.**  
**PETERSBURG ALASKA 99833**

### PIPING LEGEND

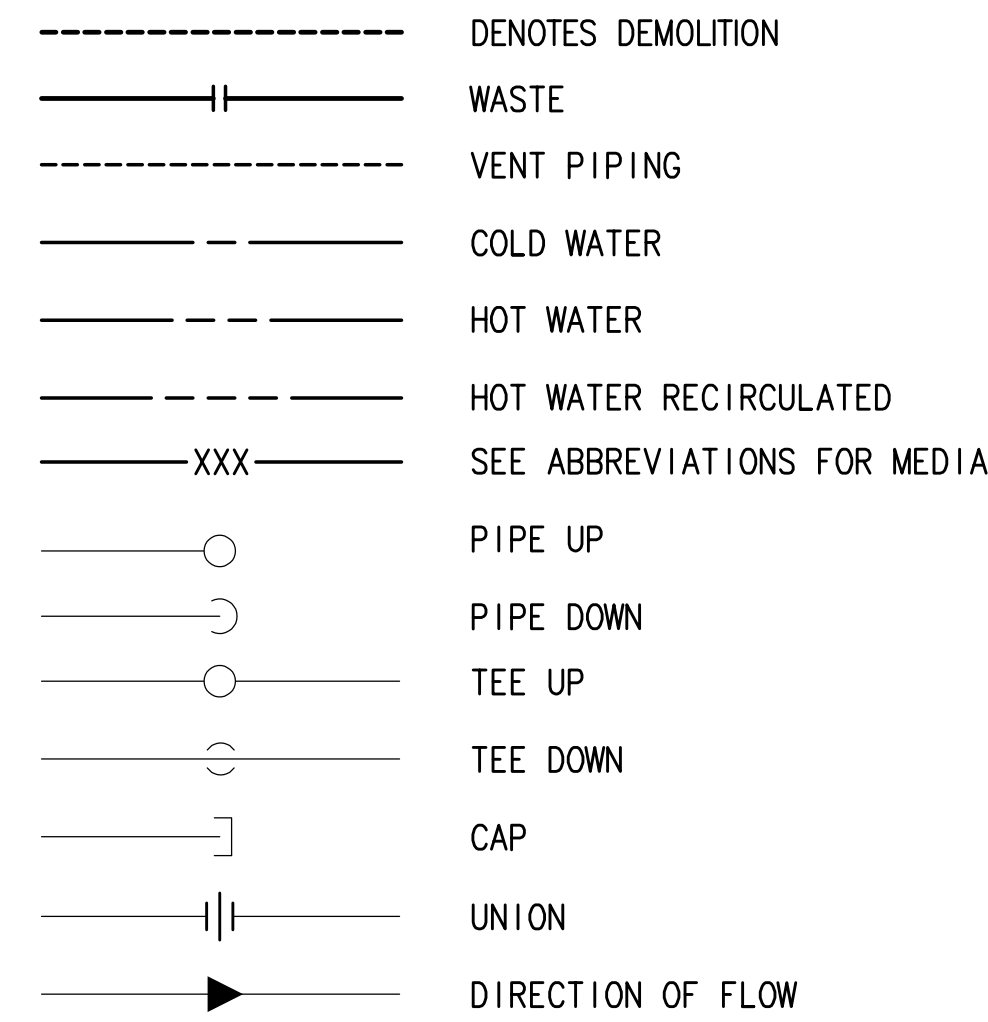

### DUCTWORK LEGEND

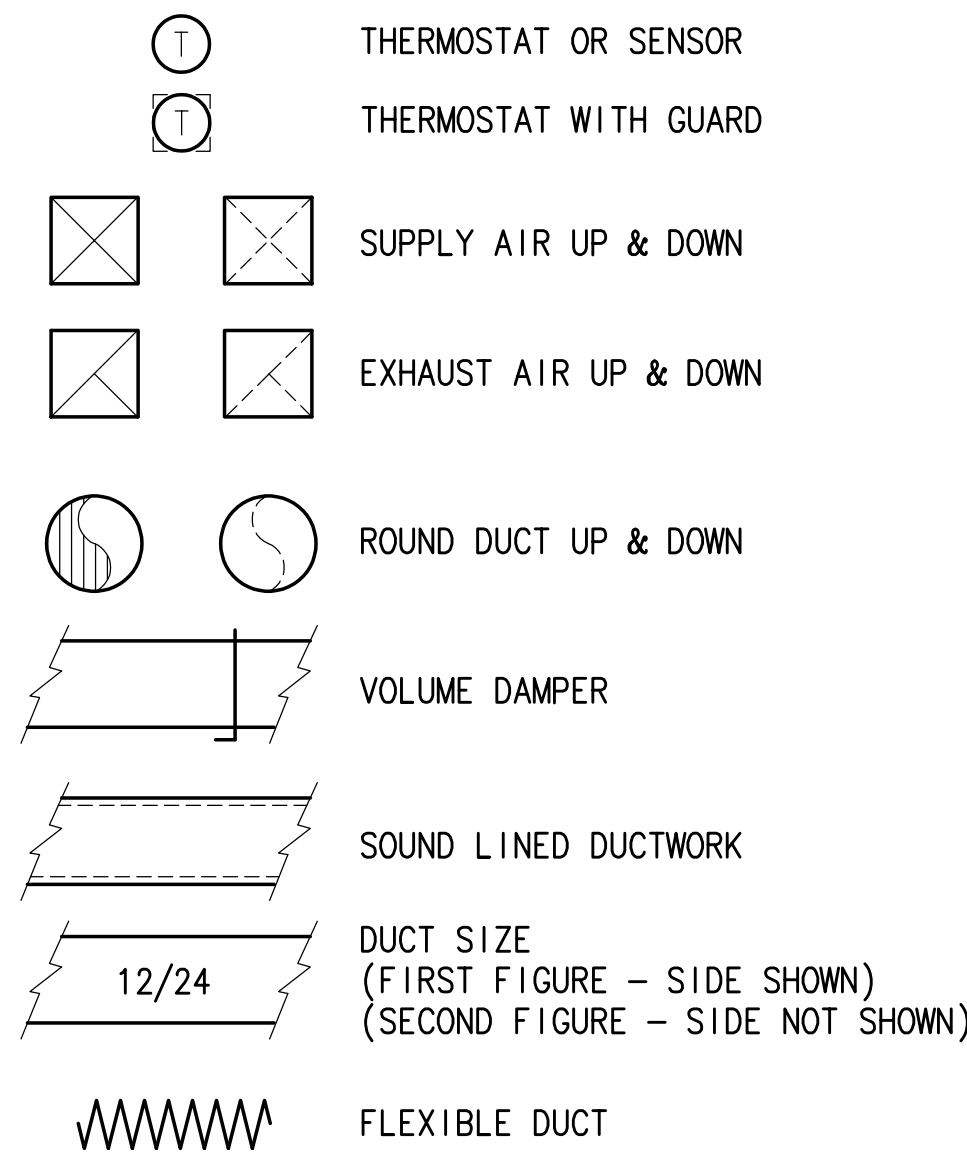

### LOGIC

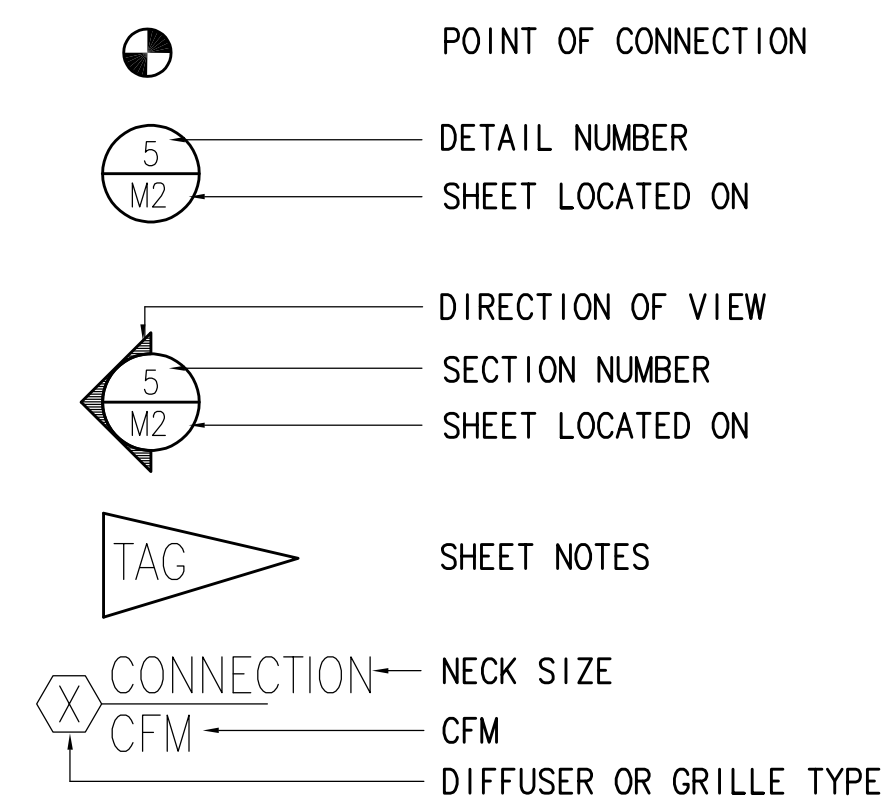

### ABBREVIATIONS

ADA	AMERICAN WITH DISABILITIES ACT GUIDELINES	HWR	HOT WATER RETURN
AMPS	AMPERES	IN	INCHES
ARCH	ARCHITECTURAL	IN. WC.	INCHES WATER COLUMN
BLDG	BUILDING	LAT	LEAVING AIR TEMPERATURE
BTUH	BRITISH THERMAL UNIT/HOUR	LWT	LEAVING WATER TEMPERATURE
CAP	CAPACITY	MBH	THOUSAND BTUH
CFM	CUBIC FEET PER MINUTE	MFGR	MANUFACTURER
CIRC	CIRCULATING	MIN	MINIMUM
C.O./CO	CLEANOUT	MTD	MOUNTED
CONN	CONNECTION	NC	NOISE CRITERIA
CW	COLD WATER	N.C.	NORMALLY CLOSED
dB	DECIBELS	NO.	NUMBER
DDC	DIRECT DIGITAL CONTROL	N.O.	NORMALLY OPEN
DEG	DEGREE	P-X	PLUMBING FIXTURE DESIGNATOR
DIA	DIAMETER	PD	PRESSURE DROP
DN	DOWN	PH	PHASE
E/A	EXHAUST AIR	PSI	POUND PER SQUARE INCH
EAT	ENTERING AIR TEMPERATURE	R/A	RETURN AIR
EF-X	EXHAUST FAN DESIGNATOR	RPM	REVOLUTIONS PER MINUTE
ESP	EXTERNAL STATIC PRESSURE	S/A	SUPPLY AIR
EXIST	EXISTING	SP	STATIC PRESSURE
F	FAHRENHEIT	TEMP	TEMPERATURE
FT	FEET	T'STAT	THERMOSTAT
FT-X	FINNED TUBE RADIATION DESIGNATOR	TYP	TYPICAL
FCO	FLOOR CLEAN OUT	V	VENT
FLA	FULL LOAD AMPS	VTR	VENT THRU ROOF
FT	FEET	W	WASTE
GA	GAUGE	W/	WITH
GAL	GALLONS	WC	WATER COLUMN
GPH	GALLONS PER HOUR	WG	WATER GAUGE
GPM	GALLONS PER MINUTE	WHA	WATER HAMMER ARRESTOR
HD	HEAD	WPD	WATER PRESSURE DROP
HP	HORSEPOWER		
HW	HOT WATER		
HWC	HOT WATER CIRCULATED		
HWS	HOT WATER SUPPLY		

### PLUMBING FIXTURE SCHEDULE

SYMBOL	FIXTURE	MANUFACTURER	MODEL	CW	HW/TW	WASTE	VENT	TRAP	COLOR/FINISH	TRIM/REMARKS
P-1	WATER CLOSET	EXISTING	EXISTING	1	--	4	2	--	WHITE	EXISTING WATER CLOSET WITH FLUSH VALVE
P-2	WATER CLOSET - ADA	EXISTING	EXISTING	1	--	4	2	--	WHITE	EXISTING ADA WATER CLOSET WITH FLUSH VALVE
P-3	URINAL	EXISTING	EXISTING	1/2	--	2	1-1/2	1-1/2	WHITE	EXISTING URINAL WITH FLUSH VALVE
P-4	URINAL - ADA	EXISTING	EXISTING	1/2	--	2	1-1/2	1-1/2	WHITE	EXISTING ADA URINAL WITH FLUSH VALVE
P-5	LAVATORY - COUNTER	EXISTING	EXISTING	1/2	1/2	1-1/2	1-1/4	1-1/4	WHITE	EXISTING COUNTER MOUNTED LAVATORY
P-6	LAVATORY - WALL	EXISTING	EXISTING	1/2	1/2	1-1/2	1-1/4	1-1/4	WHITE	EXISTING WALL MOUNTED LAVATORY
P-7	ARTS AND CRAFT SINK	JUST	SL-2122-A-GR	1/2	1/2	1-1/2	1-1/2	1-1/2	STAINLESS	COUNTER MOUNTED SINK, CHICAGO FAUCET 786-GNAE3ABCP, 8" CENTERS, 8" GOOSE NECK
P-8	NOT USED	--	--							
P-9	DRINKING FOUNTAIN	EXISTING	EXISTING	1/2	1/2	1-1/2	1-1/4	1-1/4	STAINLESS	EXISTING WALL MOUNTED DRINKING FOUNTAIN
P-10	NOT USED	--	--							
P-11	SHOWER HEAD	EXISTING	EXISTING	1/2	1/2				---	EXISTING SHOWER HEAD
P-12	SHOWER STALL - ADA	EXISTING	EXISTING	1/2	1/2	2	1-1/2	2	---	EXISTING SHOWER
FD-1	FLOOR DRAIN	J.R. SMITH	2005	--	--	2	1-1/2	2	NICKEL/BRONZE	FLOOR DRAIN, RECONNECT EXISTING TRAP PRIMER IN NON-SHOWER AREAS. IF NO TRAP PRIMER EXISTS, PROVIDE JR SMITH 2692 QUAD CLOSE TRAP SEAL.

REVISIONS:

DRAWN BY: ARN  
 CHECKED BY: RRD  
 DATE: 4/7/2023  
 JOB NUMBER: M2219.00  
 DWG FILE: MSERIES

DRAWING TITLE:  
 LEGEND, SCHEDULES  
 AND ABBREVIATIONS

SHEET:  
**M001**



**SECTION 22 05 00: 23 05 00 – COMMON WORK RESULTS FOR MECHANICAL**

THE INFORMATION SHOWN ON THESE PLANS FOR EXISTING CONDITIONS IS TAKEN FROM AS-BUILT DRAWINGS AND A NON-DESTRUCTIVE INVESTIGATION OF THE FACILITY. THE INFORMATION SHOWN FOR EXISTING CONDITIONS MAY OR MAY NOT BE ACCURATE OR COMPLETE. THE CONTRACTOR SHALL FIELD VERIFY ALL ITEMS SCHEDULED FOR DEMOLITION PRIOR TO START OF WORK.

PLANS – THE CONTRACTOR SHALL PROVIDE ALL MATERIALS AND LABOR NECESSARY FOR A COMPLETE AND OPERABLE SYSTEM. THE DRAWINGS ARE PARTLY DIAGRAMMATIC, NOT NECESSARILY SHOWING ALL OFFSETS OR EXACT LOCATIONS OF PIPING AND DUCTS UNLESS SPECIFICALLY DIMENSIONED. CONTRACTOR IS TO COORDINATE PIPING AND EQUIPMENT LOCATIONS WITH ARCHITECTURAL, STRUCTURAL, AND ELECTRICAL PLANS TO AVOID CONFLICTS. REVIEW THE DRAWINGS AND SPECIFICATIONS FOR EQUIPMENT FURNISHED BY OTHER CRAFTS BUT INSTALLED IN ACCORDANCE WITH THIS SECTION. BRING QUESTIONABLE OR OBSCURE ITEMS, APPARENT CONFLICTS BETWEEN PLANS AND SPECIFICATIONS, GOVERNING CODES OR UTILITY REGULATIONS TO THE ATTENTION OF THE OWNER. CODES, ORDINANCES, REGULATIONS, STANDARDS, OR MANUFACTURER’S INSTRUCTIONS TAKE PRECEDENCE WHEN THEY ARE MORE STRINGENT OR CONFLICT WITH THE DRAWINGS AND SPECIFICATIONS. COORDINATE WITH PHASING PLAN TO PERFORM COORDINATED WORK IN SEQUENCE WITH OTHER TRADES. MAINTAIN CODE MINIMUM MECHANICAL SERVICE TO ALL AREAS IMPACTED BY WORK WHERE STILL OCCUPIED BY THE OWNER.

STANDARDS, CODES, AND REGULATIONS – ALL WORK SHALL BE DONE IN ACCORDANCE WITH THE LATEST ADOPTED EDITION OF THE INTERNATIONAL BUILDING CODE (IBC), INTERNATIONAL MECHANICAL CODE (IMC), UNIFORM PLUMBING CODE(UPC), AS AMENDED BY THE STATE OF ALASKA.

PERMITS – THE CONTRACTOR SHALL SECURE AND PAY FOR ALL NECESSARY PERMITS AND FEES. NOT PROVIDED BY THE OWNER.

SUBMITTALS – SUBMITTALS SHALL BE IN ELECTRONIC FORM. THE DATA SHALL BE ARRANGED AND BOOKMARKED BY SPECIFICATION SECTION. SUBMIT ON ALL SCHEDULED EQUIPMENT AND ALL MATERIALS AND EQUIPMENT AS NOTED IN THE SPECIFICATIONS.

MATERIALS – ALL MATERIALS OTHER THAN OWNER SUPPLIED SHALL BE NEW AND UNUSED, INSTALLED IN ACCORDANCE WITH THE MANUFACTURER’S DIRECTIONS AND IN THE BEST PRACTICE OF THE CRAFT. OBTAIN OWNER APPROVAL OF ALL PRODUCTS PRIOR TO ORDERING OR INSTALLING ANY PART OF ANY SYSTEM.

EQUIPMENT SUBSTITUTIONS – ALL EQUIPMENT LISTED AND SCHEDULED ARE REPRESENTATIVE OF THE STANDARD OF QUALITY AND PERFORMANCE REQUIRED. "OR EQUAL" SUBSTITUTIONS WILL BE CONSIDERED IF SUBSTITUTE DATA SHEETS ARE SUBMITTED AND ARE SHOWN TO BE OF EQUAL OR BETTER QUALITY, INCLUDING EFFICIENCY OF PERFORMANCE, AND SIZE AND WEIGHT. OWNER SHALL HAVE FIRST RIGHT OF REFUSAL FOR ALL SUBSTITUTIONS.

WORKMANSHIP – INSTALLATION OF ALL WORK SHALL BE MADE SO THAT ITS SEVERAL COMPONENT PARTS SHALL FUNCTION AS A WORKABLE SYSTEM COMPLETE WITH ALL ACCESSORIES NECESSARY FOR ITS OPERATION. ALL MATERIAL AND EQUIPMENT SHALL BE INSTALLED IN ACCORDANCE WITH THE MANUFACTURER’S RECOMMENDATIONS, INSTRUCTIONS AND/OR INSTALLATION DRAWINGS. MATERIALS AND EQUIPMENT SHALL BE NEW AND SHALL CONFORM WITH APPLICABLE INDUSTRY STANDARDS, AND THIRD PARTY LISTINGS WHERE APPLICABLE.

WARRANTY – ALL WORK PERFORMED UNDER THIS CONTRACT SHALL BE FREE FROM DEFECTS IN MATERIALS AND WORKMANSHIP FOR A PERIOD OF ONE YEAR FROM PROJECT COMPLETION AND OWNER ACCEPTANCE. ANY FAULTY MATERIALS OR WORKMANSHIP SHALL BE REPAIRED OR REPLACED TO THE SATISFACTION OF THE OWNER DURING THE WARRANTY PERIOD.

EQUIPMENT INSTALLATION AND ACCESS – INSTALL ALL EQUIPMENT WHERE NOTED ON THE DRAWINGS IN ACCORDANCE WITH THE MANUFACTURER’S INSTRUCTIONS. PROVIDE MISCELLANEOUS APPURTENANCES IN ACCORDANCE WITH THE MANUFACTURER’S INSTRUCTIONS INCLUDING ACCESSORIES, SUPPORTS AND CONTROL CONNECTIONS REQUIRED FOR COMPLETE AND OPERATING SYSTEMS. MAINTAIN MANUFACTURER’S RECOMMENDED SERVICE CLEARANCES AND PROVIDE WORKABLE ACCESS TO ALL SERVICEABLE AND/OR OPERABLE EQUIPMENT.

TEST AND START-UP – TEST ALL PLUMBING AND PIPING SYSTEMS IN ACCORDANCE WITH THE UNIFORM PLUMBING CODE (UPC).

RECORD DRAWINGS – PROVIDE ACCURATE PROJECT RECORD DRAWINGS, SHOWN IN RED INK ON A CLEAN SET OF PRINTS. SHOWING ALL CHANGES FROM THE ORIGINAL PLANS MADE DURING INSTALLATION OF THE WORK. SHOW THE DIMENSIONED LOCATION AND ROUTING OF ALL MECHANICAL WORK THAT IS PERMANENTLY CONCEALED. SHOW ROUTING OF WORK IN PERMANENTLY CONCEALED BLIND SPACES WITHIN THE

BUILDING. SHOW COMPLETE ROUTING AND SIZING OF ANY SIGNIFICANT REVISIONS TO THE SYSTEMS SHOWN. SUBMIT ORIGINAL COPY TO OWNER AT THE COMPLETION OF WORK AND PRIOR TO SUBSTANTIAL COMPLETION INSPECTION.

DEMOLITION DRAWINGS ARE BASED ON AS-BUILT DRAWINGS AND A NON-DESTRUCTIVE WALK-THROUGH OF THE FACILITY. REPORT DISCREPANCIES TO OWNER BEFORE DISTURBING THE EXISTING INSTALLATION. DISABLE SYSTEMS ONLY TO MAKE SWITCH OVERS AND CONNECTIONS. COORDINATE WITH PHASING PLAN TO PERFORM WORK IN SEQUENCE WITH OTHER TRADES AND MAINTAIN CODE MINIMUM MECHANICAL SERVICE CLEARANCES TO ALL AREAS IMPACTED BY WORK AND STILL OCCUPIED. OBTAIN PERMISSION FROM OWNER AT LEAST 72 HOURS PRIOR TO PARTIALLY OR COMPLETELY DISABLING SYSTEM. MINIMIZE OUTAGE DURATION AND MAKE TEMPORARY CONNECTIONS TO MAINTAIN SERVICE IN AREAS ADJACENT TO WORK AREAS. REMOVE EXPOSED ABANDONED PIPING, INSULATION, HANGERS AND SUPPORTS, CONTROLS AND CONTROL WIRING, AND ANY OTHER ABANDONED MECHANICAL EQUIPMENT. WHERE ABANDONED PIPE ENTERS EXISTING SURFACES TO REMAIN, CUT PIPE FLUSH WITH WALLS, AND FLOORS, CAP/PLUG PIPE AND PATCH SURFACES. REPAIR ADJACENT CONSTRUCTION AND FINISHES DAMAGED DURING DEMOLITION AND REMODEL WORK. MAINTAIN ACCESS TO EXISTING MECHANICAL INSTALLATIONS WHICH REMAIN ACTIVE.

**SECTION 22 05 29: 23 05 29 – HANGERS & SUPPORTS FOR PIPING & EQUIPMENT**

A. SUBMITTALS: SUBMIT PRODUCT DATA FOR APPROVAL.

B. MATERIALS:

1. PIPE HANGERS AND SUPPORTS – BELOW GRADE
  - 1.1. HANGERS FOR PIPES 1/2" TO 1-1/2" – TYPE 316 STAINLESS, ADJUSTABLE SWIVEL, SPLIT RING, TYPE 316 STAINLESS STEEL HARDWARE AND SUPPORT ROD.
  - 1.2. HANGERS FOR PIPES 2" TO 4" – TYPE 316 STAINLESS STEEL, ADJUSTABLE CLEVIS, TYPE 316 STAINLESS STEEL HARDWARE AND SUPPORT ROD .
  - 1.3. MULTIPLE OR TRAPEZE HANGERS – TYPE 316 STAINLESS STEEL CHANNELS WITH WELDED SPACERS AND HANGER RODS.
  - 1.4. WALL SUPPORTS FOR PIPES 1/2" TO 3" – TYPE 316 STAINLESS STEEL HOOK.
  - 1.5. WALL SUPPORTS FOR PIPES 4" AND LARGER – WELDED TYPE 316 STAINLESS STEEL BRACKET, STAINLESS STEEL CLAMP.

C. INSTALLATION

1. DESIGNED AND INSTALLED IN ACCORDANCE WITH THE UNIFORM PLUMBING CODE (UPC) FOR DOMESTIC WASTE, VENT, AND WATER PIPING
2. INSTALLED AS PER THE MANUFACTURERS INSTRUCTIONS. PROVIDE SEISMIC SUPPORT FOR ALL PIPING AND EQUIPMENT IN ACCORDANCE WITH IBC.

**SECTION 22 10 00 – PLUMBING PIPING**

A. SUBMITTALS: SUBMIT PRODUCT DATA FOR APPROVAL, PIPING SYSTEM PRESSURE TEST RESULTS.

B. PIPING:

1. WASTE PIPING, BELOW GRADE – ABS SCHEDULE 40 CELLULAR CORE. PIPE AND FITTINGS SHALL BE MANUFACTURED FROM ABS COMPOUND WITH A CELL CLASS OF 42222 FOR PIPE AND 32222 FOR FITTINGS PER ASTM D 3965 AND CONFORM WITH NATIONAL SANITATION FOUNDATION STANDARD 14. ASTM D 2661 FITTINGS. ASTM D 2235 SOLVENT WELDED JOINTS.
2. WASTE PIPING, ABOVE GRADE:
 

ABS SCHEDULE 40 CELLULAR CORE. PIPE AND FITTINGS SHALL BE MANUFACTURED FROM ABS COMPOUND WITH A CELL CLASS OF 42222 FOR PIPE AND 32222 FOR FITTINGS PER ASTM D 3965 AND CONFORM WITH NATIONAL SANITATION FOUNDATION STANDARD 14. ASTM D 2661 FITTINGS. ASTM D 2235 SOLVENT WELDED JOINTS.

C. FLOOR CLEANOUT:

1. ENAMEL PAINT COATED CAST IRON, TWO PIECE BODY WITH DOUBLE DRAINAGE FLANGE, WEEP HOLES, REVERSIBLE CLAMPING COLLAR, BRONZE PLUG, AND ADJUSTABLE ROUND NICKEL BRONZE SCORIATED COVER. J.R. SMITH MODEL 4021 OR APPROVED EQUAL.

D. INSTALLATION

1. TEST ALL NEW PORTIONS OF PIPING IN ACCORDANCE WITH THE UPC.
2. INSTALL ALL PIPING IN CRAFTSMANLIKE MANNER, PLUMB AND PARALLEL TO BUILDING LINES. GROUP PIPING AT COMMON ELEVATIONS WHERE PRACTICAL.
3. PROVIDE CLEARANCE FOR INSTALLATION OF INSULATION AND ACCESS TO VALVES AND FITTINGS.

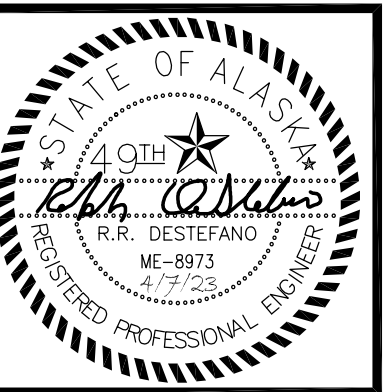

**R S A**  
**Engineering, Inc.**  
MECHANICAL AND ELECTRICAL CONSULTING ENGINEERS  
670 West Frenned Lane, Suite 200  
Anchorage, AK 99503  
Phone (907) 276-0921  
Corporate No.: AECC542

**PARKS & REC. WASTE PIPE REPAIR**

**PETERSBURG BOROUGH**  
**500 N. 3RD. ST.**  
**PETERSBURG ALASKA 99833**

REVISIONS:

DRAWN BY: ARN  
CHECKED BY: RRD  
DATE: 4/7/2023  
JOB NUMBER: M2219.00  
DWG FILE: MSERIES

DRAWING TITLE:  
MECHANICAL  
SPECIFICATIONS

SHEET:  
**M002**



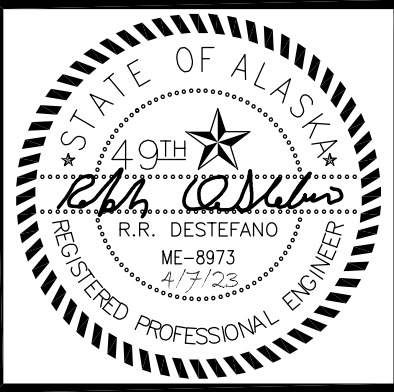

**R S A**  
**Engineering, Inc.**  
 MECHANICAL AND ELECTRICAL CONSULTING ENGINEERS  
 670 West Frenned Lane, Suite 200  
 Anchorage, AK 99503  
 Phone (907) 276-0521  
 Corporate No.: AECC542

**PARKS & REC. WASTE PIPE REPAIR**  
**PETERSBURG BOROUGH**  
**500 N. 3RD. ST.**  
**PETERSBURG ALASKA 99833**

REVISIONS:

DRAWN BY: ARN  
 CHECKED BY: RRD  
 DATE: 4/7/2023  
 JOB NUMBER: M2219.00  
 DWG FILE: MSERIES

DRAWING TITLE:  
 UNDERSLAB PLUMBING  
 DEMOITION PLAN

SHEET:  
**M101**

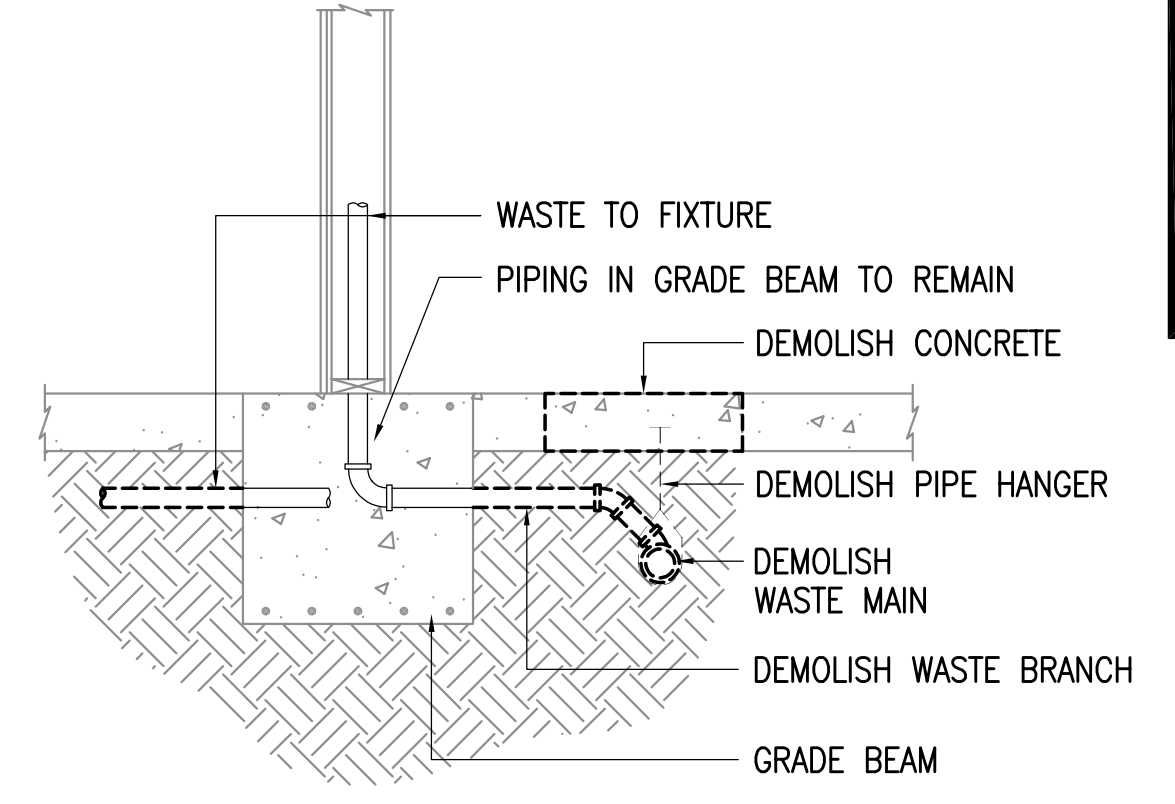

**2 WASTE PIPE DEMO DETAIL**  
 NOT TO SCALE

**GENERAL NOTES:**

- A. THE INFORMATION SHOWN ON THIS DRAWING IS TAKEN FROM AS-BUILT DRAWINGS AND A NON-DESTRUCTIVE WALKTHROUGH OF THE FACILITY. THE CONTRACTOR SHALL FIELD VERIFY ALL ITEMS SCHEDULED FOR DEMOLITION PRIOR TO START OF WORK.

**SHEET NOTES:**

- 1. DEMOLISH EXISTING WASTE LINE. FOR TYPICAL DETAIL SEE - **2** (M101)
- 2. APPROXIMATE OUTLINE OF CONCRETE SLAB TO BE REMOVED.

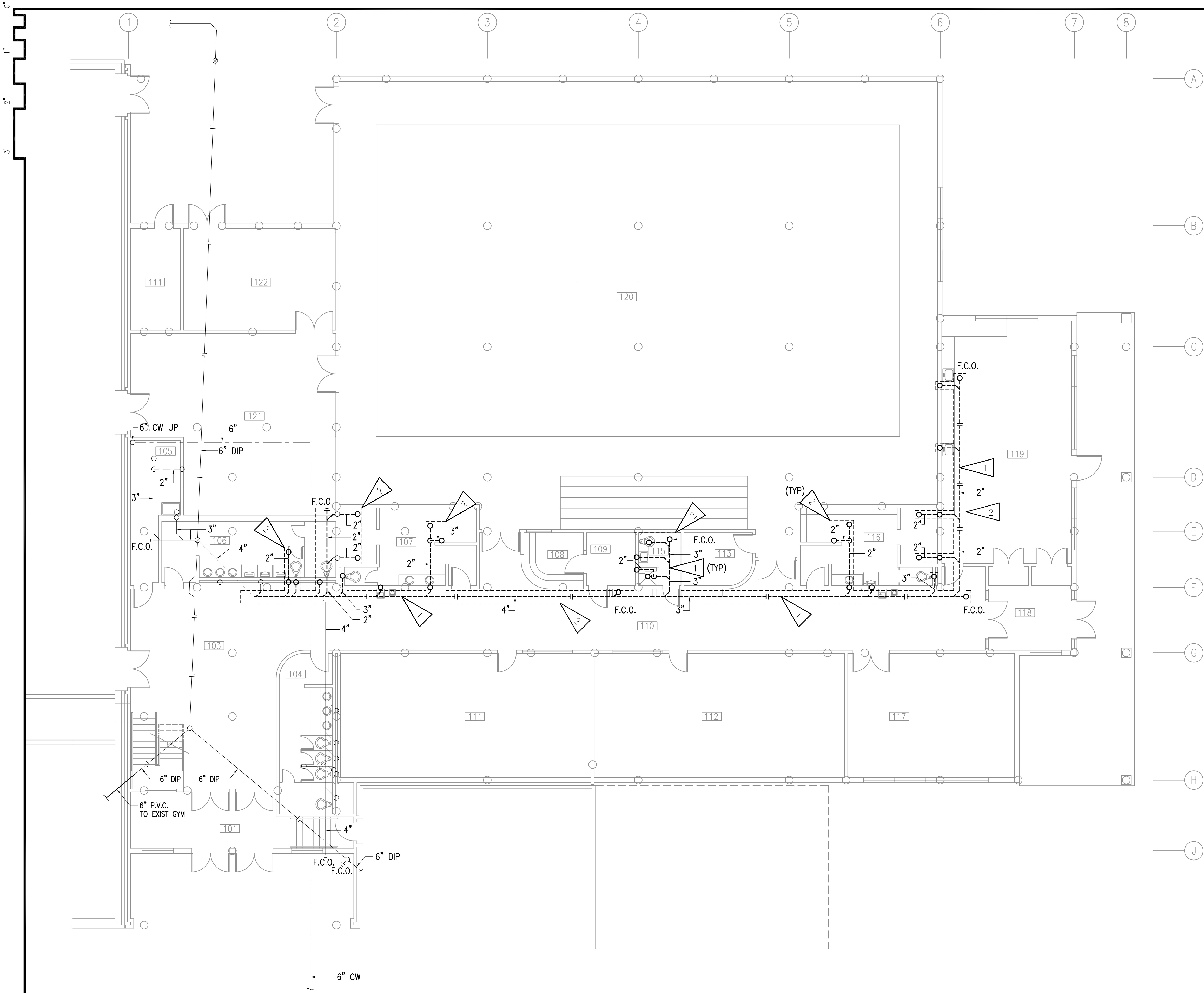

**1 UNDERSLAB PLUMBING DEMOLITION PLAN**  
 1/8" = 1'-0"





**RSA**  
**Engineering, Inc.**  
 MECHANICAL AND ELECTRICAL CONSULTING ENGINEERS  
 670 West Freewood Lane, Suite 200  
 Anchorage, AK 99503  
 Phone (907) 276-0521  
 Corporate No.: AECC542

**PARKS & REC. WASTE PIPE REPAIR**  
**PETERSBURG BOROUGH**  
**500 N. 3RD. ST.**  
**PETERSBURG ALASKA 99833**

REVISIONS:

DRAWN BY: ARN  
 CHECKED BY: RRD  
 DATE: 4/7/2023  
 JOB NUMBER: M2219.00  
 DWG FILE: MSERIES

DRAWING TITLE:  
 ABOVE FLOOR PLUMBING  
 DEMOLITION PLAN

SHEET:  
**M102**

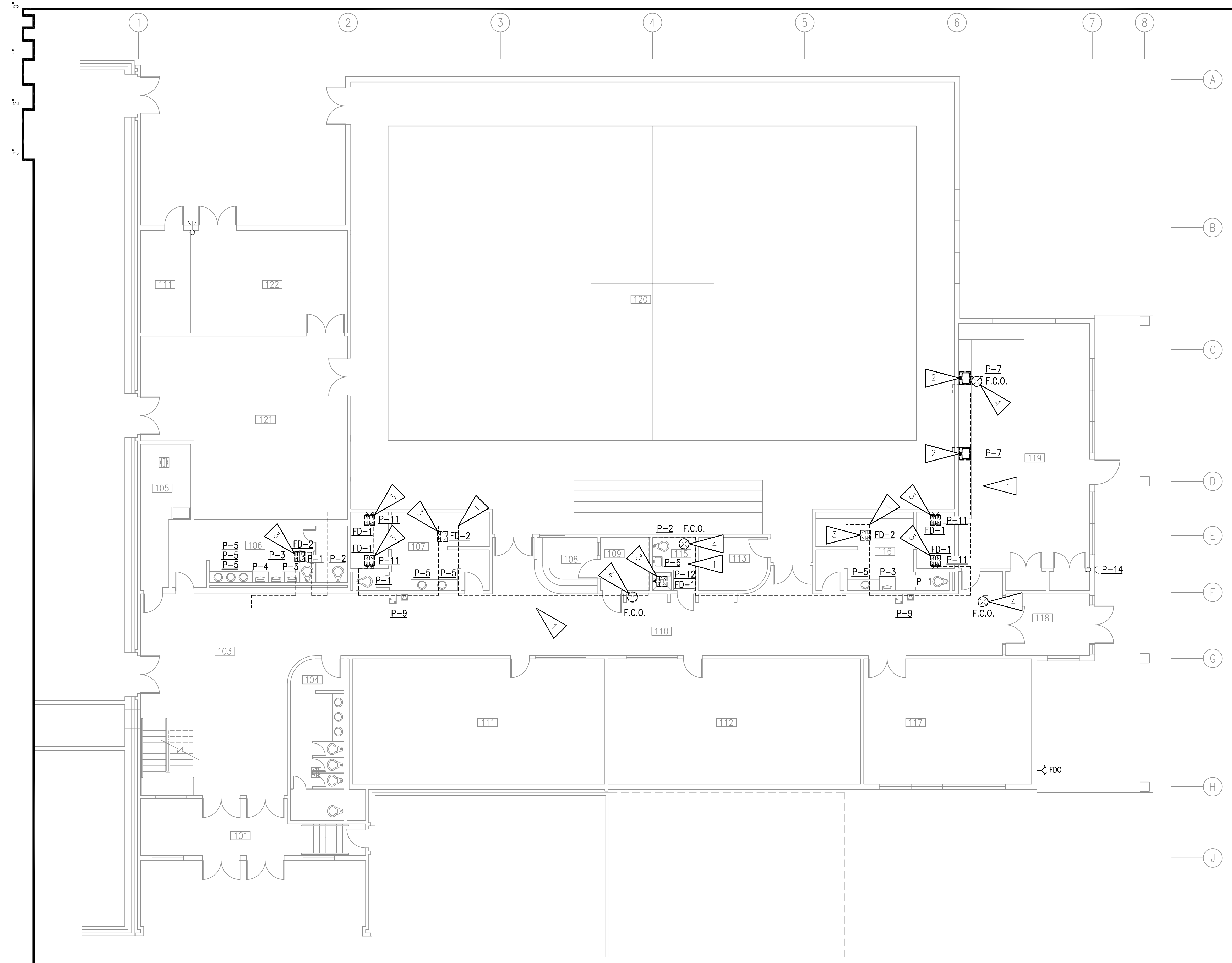

**GENERAL NOTES:**

- A. THE INFORMATION SHOWN ON THIS DRAWING IS TAKEN FROM AS-BUILT DRAWINGS AND A NON-DESTRUCTIVE WALKTHROUGH OF THE FACILITY. THE CONTRACTOR SHALL FIELD VERIFY ALL ITEMS SCHEDULED FOR DEMOLITION PRIOR TO START OF WORK.

**SHEET NOTES:**

1. APPROXIMATE OUTLINE OF CONCRETE SLAB TO BE REMOVED.
2. DEMOLISH PLUMBING FIXTURE.
3. DEMOLISH FLOOR DRAIN.
4. DEMOLISH FLOOR CLEANOUT

**1** ABOVE FLOOR PLUMBING DEMOLITION PLAN  
 1/8" = 1'-0"





**R S A**  
**Engineering, Inc.**  
 MECHANICAL AND ELECTRICAL CONSULTING ENGINEERS  
 670 West Frensdal Lane, Suite 200  
 Anchorage, AK 99503  
 Phone (907) 276-0521  
 Corporate No.: AECC542

**PARKS & REC. WASTE PIPE REPAIR**  
**PETERSBURG BOROUGH**  
**500 N. 3RD. ST.**  
**PETERSBURG ALASKA 99833**

REVISIONS:

DRAWN BY: ARN  
 CHECKED BY: RRD  
 DATE: 4/7/2023  
 JOB NUMBER: M2219.00  
 DWG FILE: MSERIES

DRAWING TITLE:  
 UNDERSLAB PLUMBING  
 REMODEL PLAN

SHEET:  
**M201**

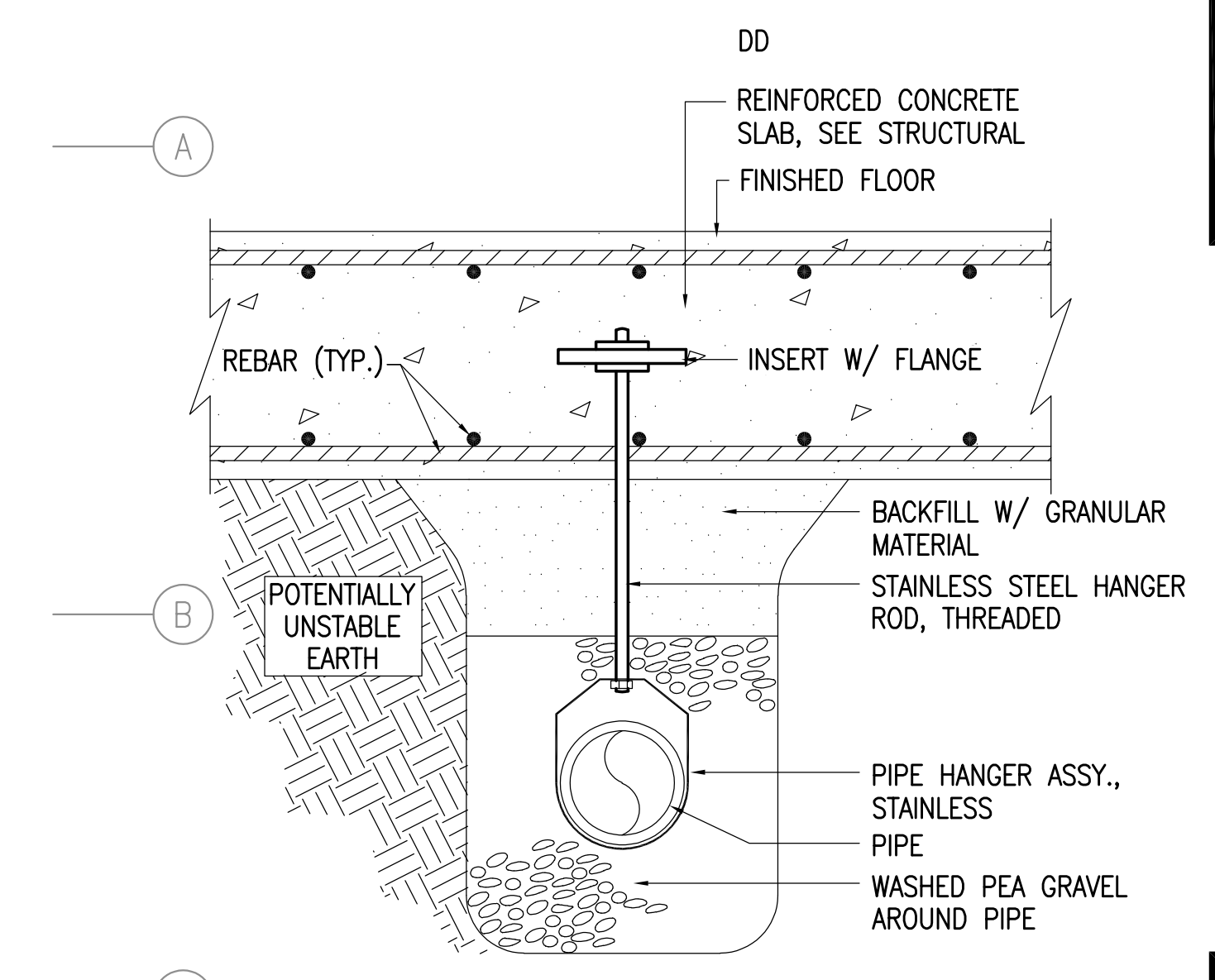

**2 BELOW GRADE PIPE HANGER**  
 NOT TO SCALE

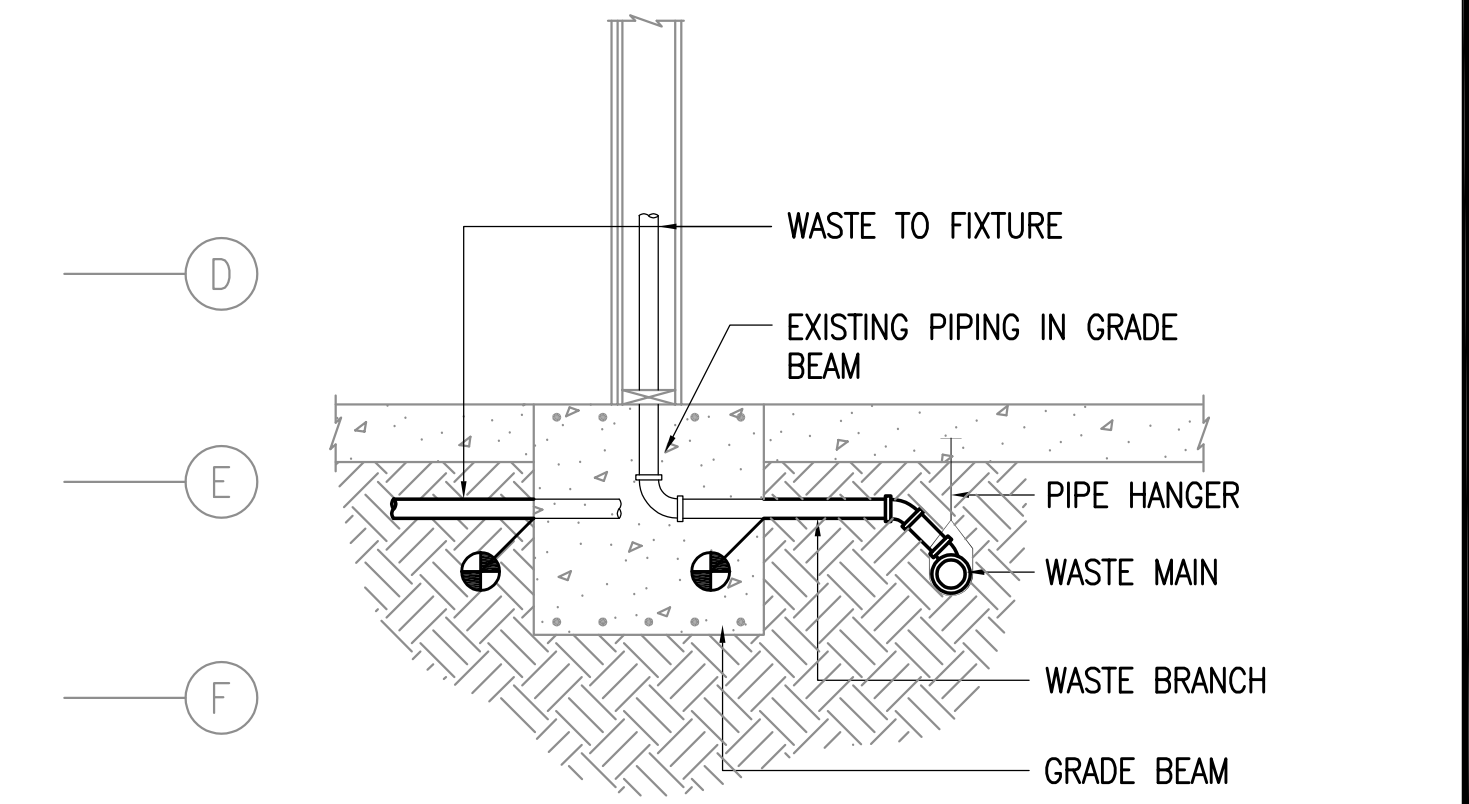

**3 WASTE PIPE REMODEL DETAIL**  
 NOT TO SCALE

**GENERAL NOTES:**

- A. WASTE PIPING IS TO BE SUPPORTED FROM THE SLAB ABOVE SEE DETAIL - **2** M201

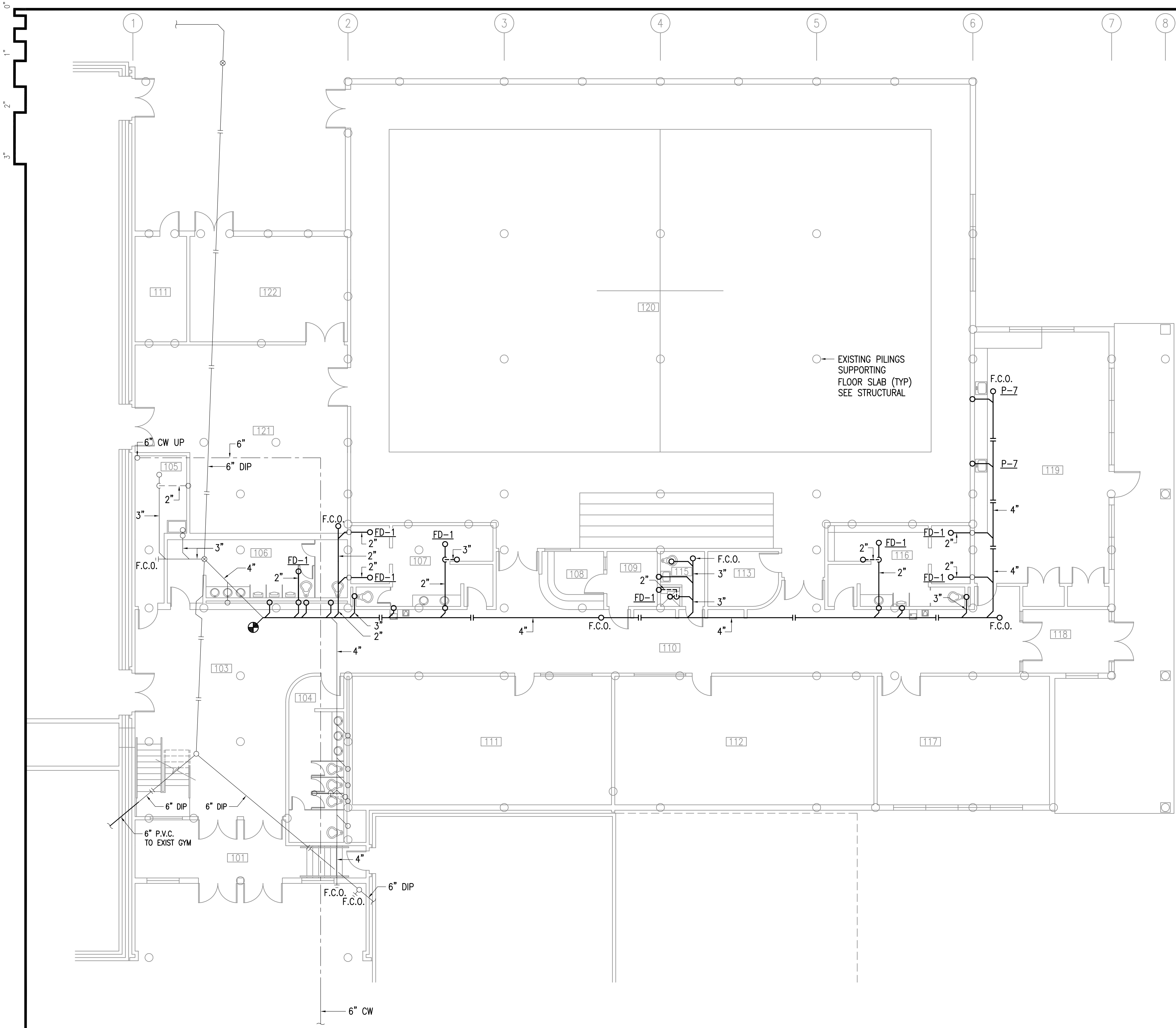

**1 UNDERSLAB PLUMBING REMODEL PLAN**  
 1/8" = 1'-0"





**RSA**  
**Engineering, Inc.**  
 MECHANICAL AND ELECTRICAL CONSULTING ENGINEERS  
 670 West Fireweed Lane, Suite 200  
 Anchorage, AK 99503  
 Phone (807) 276-0521  
 Corporate No.: AECC542

**PARKS & REC. WASTE PIPE REPAIR**

**PETERSBURG BOROUGH**  
**500 N. 3RD. ST.**  
**PETERSBURG ALASKA 99833**

REVISIONS:

DRAWN BY: ARN  
 CHECKED BY: RRD  
 DATE: 4/7/2023  
 JOB NUMBER: M2219.00  
 DWG FILE: MSERIES

DRAWING TITLE:  
**ABOVE FLOOR PLUMBING  
 REMODEL PLAN**

SHEET:  
**M202**

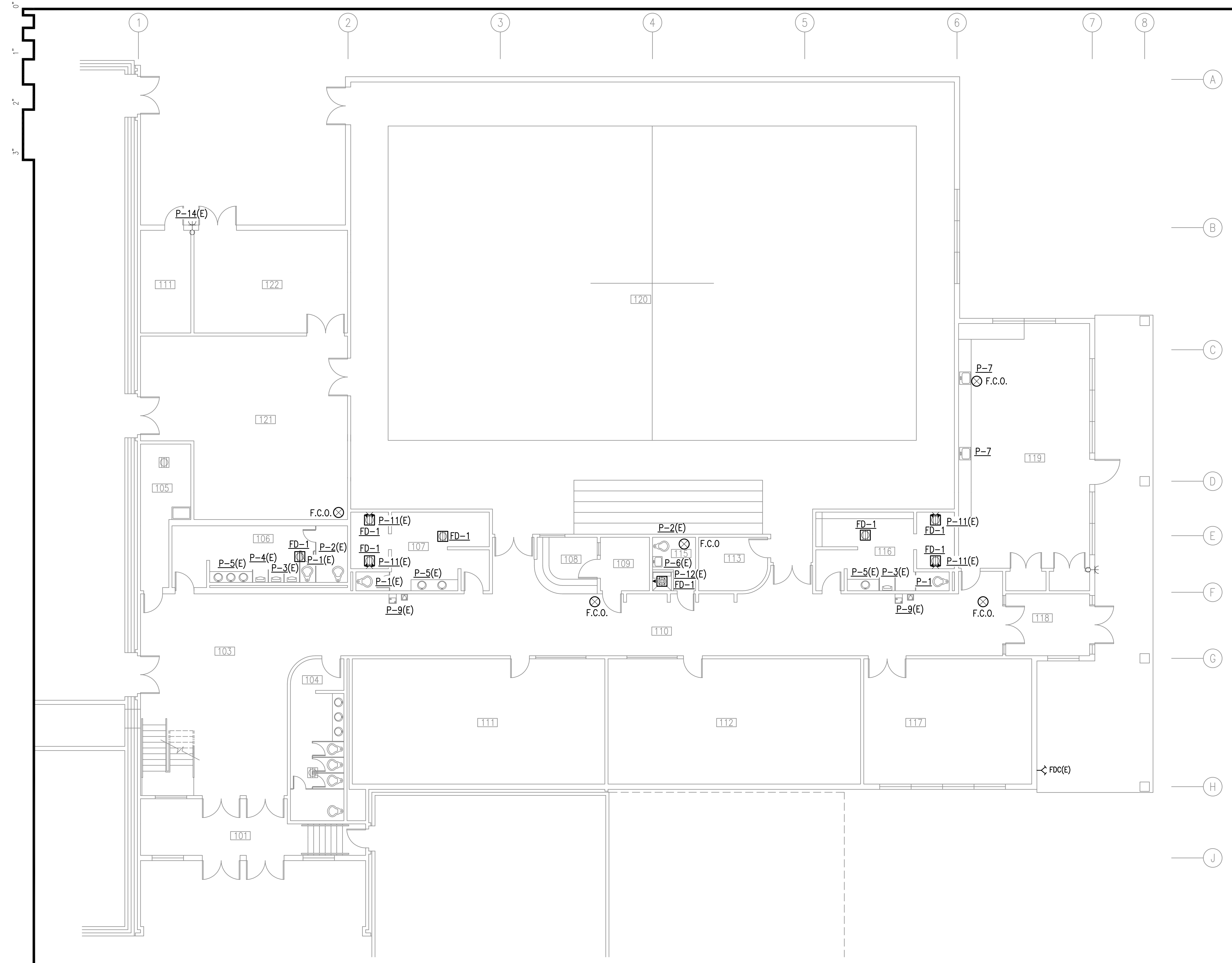

**1 ABOVE FLOOR PLUMBING REMODEL PLAN**  
 1/8" = 1'-0"